

Thermal Gate Hot Runner Series



THERMOPLAY[®]
HotRunnerSystems

 A business of BARNES GROUP INC



Experience gained in engineering and production of hot runner systems for moulding plastic materials has allowed Thermoplay to develop a complete range of nozzles and standard manifolds, for any market or application.

Important research and the necessity for continued product improvement are Thermoplay's main objectives; we have always been aware of customer requests in a constantly evolving market.

Our technical and sales teams can respond to any request for an estimate or technical consulting within 24 hours.

With this catalogue, we would like to provide all users of our systems with necessary tools to simplify application.



© Copyright 2020 - Thermoplay S.p.a.

No part of this publication may be reproduced or transmitted in any form or by any electronic or mechanical means, including photocopy, recording, or any information storage and retrieval system, without permission in writing from THERMOPLAY Company.

THERMOPLAY S.p.A. company reserves the right to make changes at any moment, in this publication, without notice.



Packaging

- High production volumes
- Reduction of plastic materials/ thin walls
- Family molds
- Frequent colour changes
- Minimised injection point
- Maximum flow rates and injection speeds
- High injection pressures
- In mold Labeling
- Recyclable / Eco materials
- Thin wall requirement
- Food compatible
- Energy saving / Low environmental impact
- Fast cooling cycle

Caps & Closures

- 2 material multicavity applications
- Reduction of plastic materials
- Right balance between size of nozzle / piece to be manufactured
- Frequent colour changes
- Minimized injection point
- High-cavitation, high-speed molds
- Large volumes requirements
- Tight pitch in compact molds
- Injection in critical gate positions
- Internal injection
- Recyclable materials / eco materials



Personal care

- High quality and transparency
- Very aesthetic injection points
- Injection in critical gate positions
- Internal injection
- Multi material injection
- Partly high thickness piece injection
(Surlyn, PCTA, PCTG)

Medical

- Wide range of global application
- High quality requirements
- Reproducibility
- Process reliability
- Clean and hygienic surface quality

Multi Cavity Hot Runner Systems

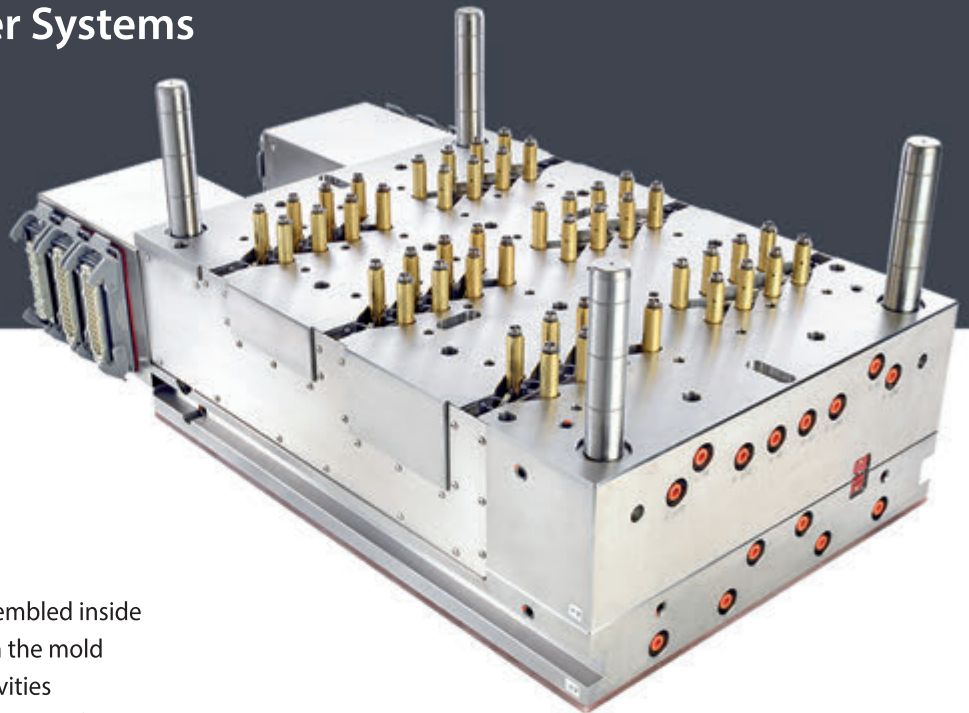

- Complete hot runner systems already assembled inside the manifold base, ready to be installed in the mold
- Hot half multi cavity systems up to 144 cavities
- Calculation of correct balance between the size of the molded parts and the nozzles in order to achieve the best cycle time
- Optimum design of mold oriented cooling system in the hot half
- Pre wired and pre tested
- High quality standards, reliability and productivity



- Improved process window
- Increased flow channels to optimize injection and decrease pressure loss
- Special patented heater:
 - uniform thermal profile
 - significant energy saving
- Tips in special steel:
 - optimal thermal conduction
 - wear resistant
 - wide range of types available
 - suitable for injection of the most used polymers
- Different lengths available
- The thermocouple is positioned close to the tip zone for a more accurate temperature reading
- Heater and the thermocouple can be replaced directly in the injection machine
- Double sealing feature on the nozzle tip and head





1

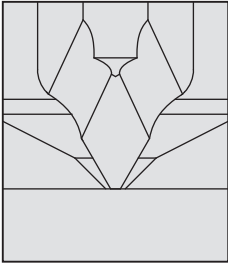

Nozzle suitable for molding parts where good injection point appearance is required. Recommended for all polymers also with abrasive fillers.

1B15

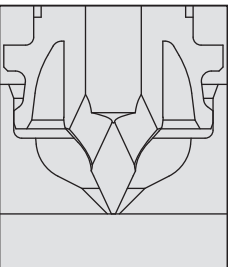

Nozzle suitable for molding parts where good injection point appearance is required. Fitted with extended tip of 1,5 mm to be housed in areas where the space is limited. Suitable for molding thin parts that require fast cycles. The nozzle is suitable for molding materials with abrasive fillers with maximum 20%. The nozzle is not suitable for quick colour changes.

1B35

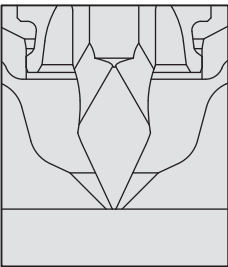

Nozzle suitable for molding parts where good injection point appearance is required. Fitted with extended tip of 3.5 mm to be housed in areas where the space is limited. Suitable for molding thin parts that require fast cycles. Moreover, the heating area is distant from the surface of the piece to limit haloing and imperfections on the molded part. The nozzle is not suitable for molding materials with abrasive fillers and to perform quick colour changes. For materials with very high fluidity only.

1B50

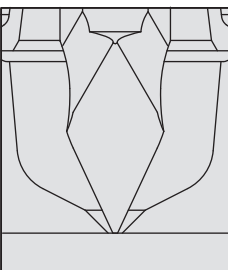

Nozzle suitable for molding parts where good injection point appearance is required. Fitted with extended tip of 5 mm to be housed in areas where the space is limited. Suitable for molding thin parts that require fast cycles. Moreover, the heating area is distant from the surface of the piece to limit halos and imperfections on the molded part. The nozzle is not suitable for molding materials with abrasive fillers. This nozzle is suitable mainly to inject polyolefin and polymers with high fluidity.

1GLT

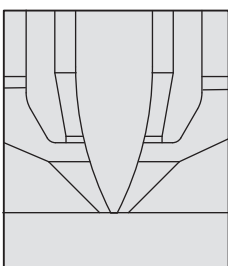

Nozzle suitable for molding parts where appearance is of great importance. This particular tip shape allows for a uniform material distribution, therefore reducing flow paths. The application market of this nozzle is mostly cosmetics and packaging, where the appearance of the molded part is very important.



1DSLA

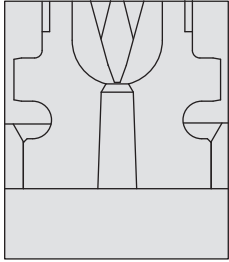

Nozzle suitable for molding on sprues or directly in cavities, leaving a small sprue on the molded part. This nozzle is suitable for molding materials with abrasive fillers. Unlike the type 1 nozzle, the machining of the die seal can be carried out from the mold cavity side. The strengthened tip allows the execution of larger sprues. A circular mark of the tip will remain on the molded part.

1DSL

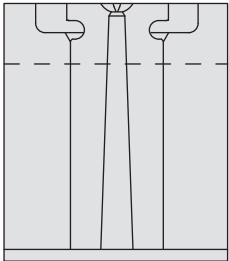

Nozzle suitable for molding on sprues or directly in cavities, leaving a small sprue on the molded piece. This nozzle is suitable for molding materials with abrasive fillers. Unlike to the type 1 nozzle, the machining of the die seal can be carried out from the mold cavity side. The strengthened tip allows the execution of larger sprues. Compared to the type 1DSL nozzle, the tip is longer and can be shaped to follow the profile of the molded part. A circular mark will remain on the molded part.

2P

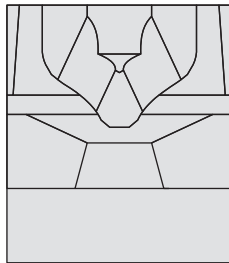

This nozzle can be used to inject on the sprue directly in the cavity, however leaving a mark evidence of the injection point. The nozzle is particularly suitable for molding materials that tend to drool. It is suitable for molding materials with abrasive fillers.

2DSL

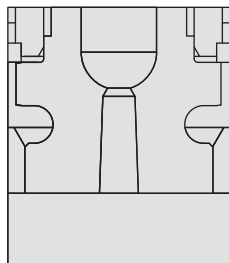

Nozzle suitable for molding on sprues or directly in cavities, leaving a small sprue on the molded part. The die can be machined to seal the nozzle from the mould cavity side. The tip has been strengthened to allow the execution of larger sprues. A circular mark will remain on the molded part. This nozzle is not suitable for molding materials that tend to drool.

2DSL

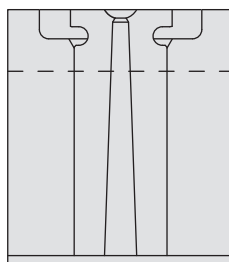

Nozzle suitable for molding on sprues or directly in cavities, leaving a small sprue on the molded part. The die can be machined to seal the nozzle from the mould cavity side. The strengthened tip allows the execution of larger sprues. A circular mark will remain on the gate of the molded part. This nozzle is not suitable for molding materials that tend to drool. Compared to the type 2DSL nozzle, the tip is longer and can be shaped to follow the profile of the molded part.

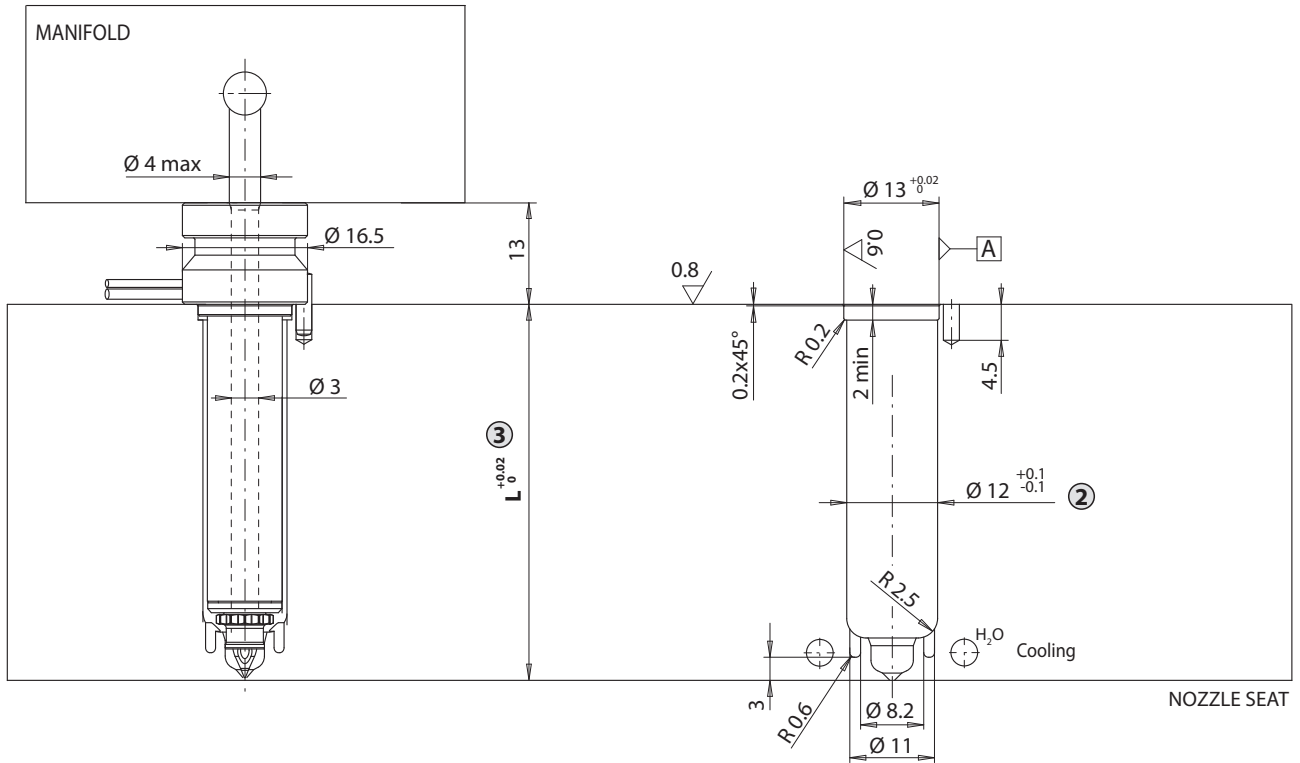

Minimum distance between nozzles centres is available on request

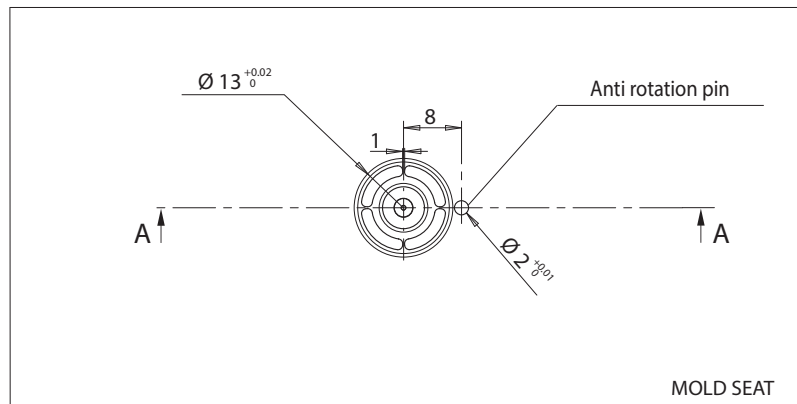
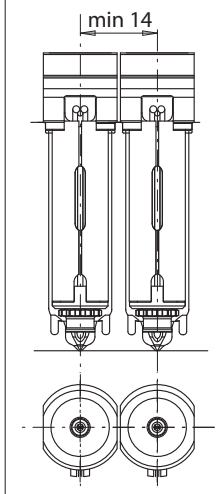

Ordering code example:

① ② ③ ④ ⑤ ⑥
T F 1 2 0 8 6 - A - 1 - J U

- ① TF Nozzle type (TF)
- ② 12 Nozzle diameter in mm (Ø12)
- ③ 086 Nozzle length in mm (L=86)
- ④ A Heater cable exit on top (A= on top)
- ⑤ 1 Tip type (1) = see next page for available tip
- ⑥ JU Thermocouple type (JU= insulated / JG= grounded)

* All measures are expressed in mm



TIP TYPE

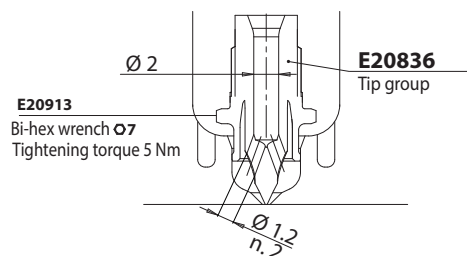
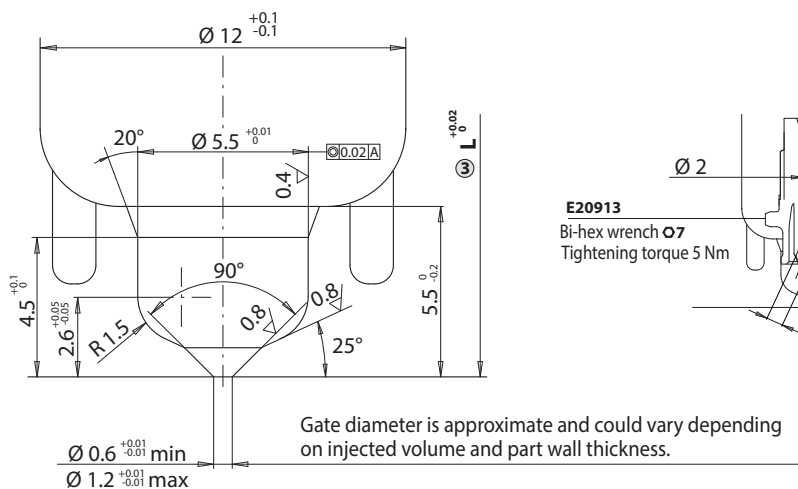
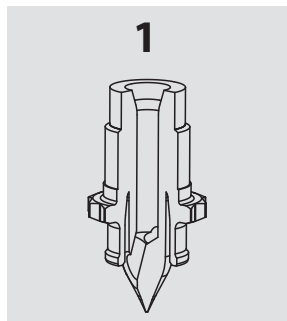

HEATER AND THERMOCOUPLE

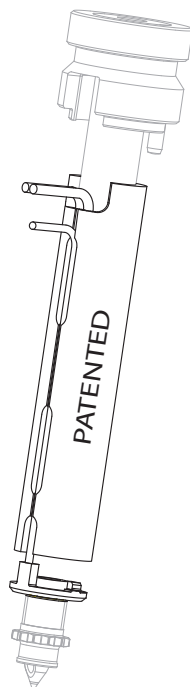

Heater length (mm) ③	Heater P/N	Watt	Thermocouple ⑥	
			grounded -JG	insulated -JU
56	E20154	130		
66	E20156	130	E20178	E20174
76	E20158	130		
86	E20160	130		
96	E20162	150	E20179	E20175
106	E20164	150		
116	E20166	150	E20180	E20176
126	E20168	150		
136	E20170	150	E20181	E20177
146	E20172	150		

- ⑥ .. -JG Grounded thermocouple with J type calibration
 .. -JU Insulated thermocouple with J type calibration

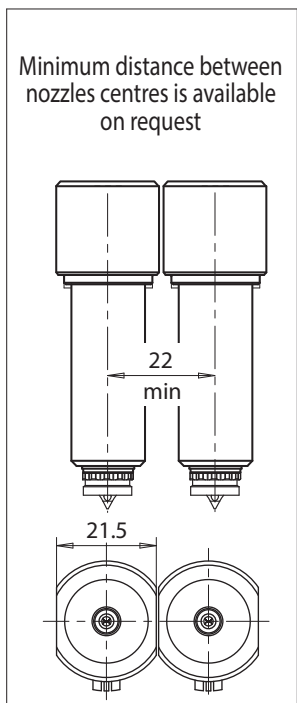
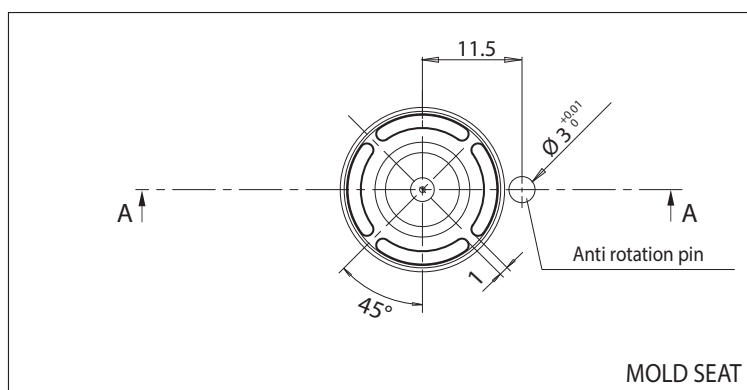
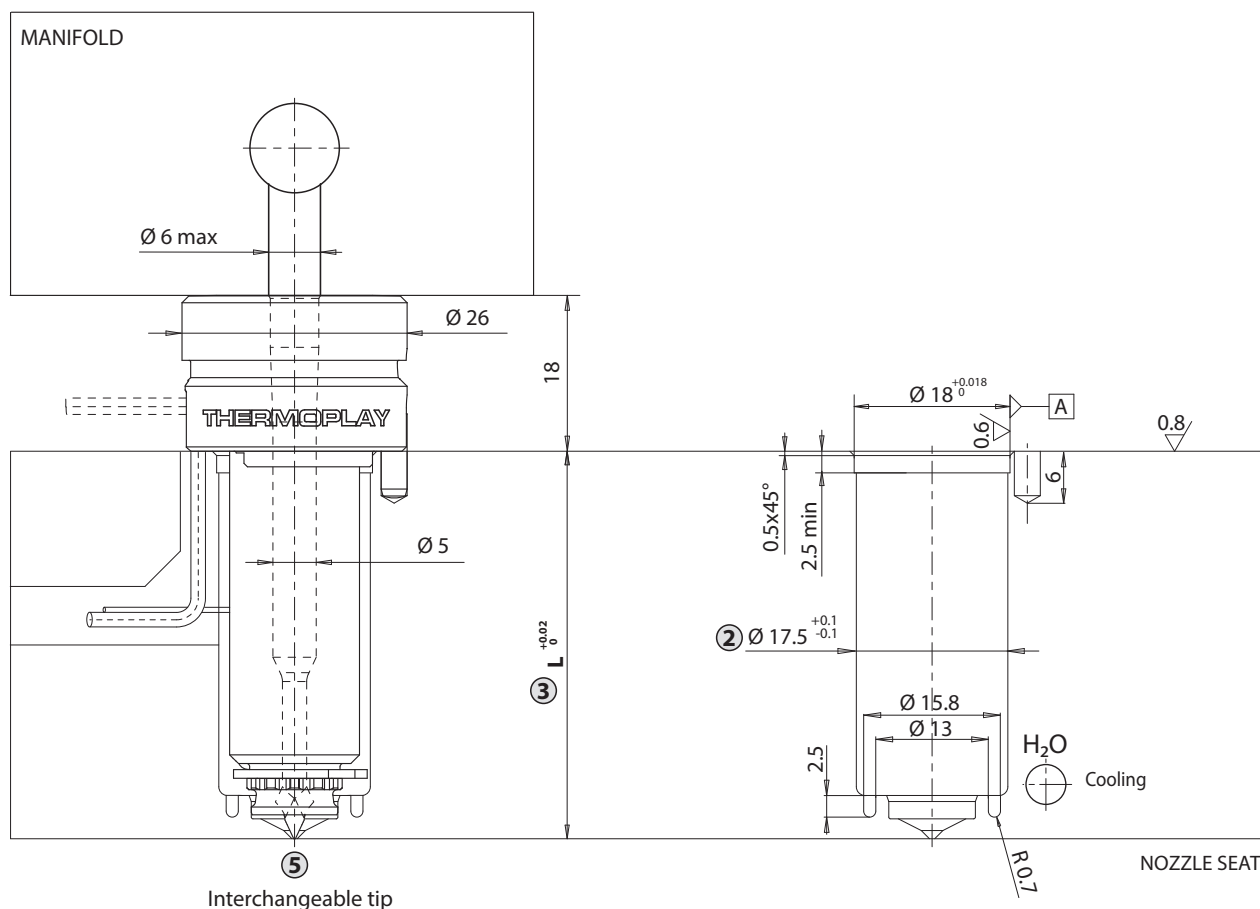

Ordering code example:

① ② ③ ④ ⑤ ⑥
TF 17 086 - A - 1 - JU

- ① TF Nozzle type (TF)
- ② 17 Nozzle diameter in mm (Ø17)
- ③ 086 Nozzle length in mm (L=86)
- ④ A Heater cable exit on top (A= top / M= middle)
- ⑤ 1 Tip type (1) = see next page for available tip
- ⑥ JU Thermocouple type (JU= insulated / JG= grounded)

* All measures are expressed in mm

TF17 nozzle



AVAILABLE TIP STYLES ⑤

Direct injection

TF-1

E18757
Bi-hex wrench $\text{Ø}10$
Tightening torque 15 Nm

E20865
Tip group

E20887
Change color bushing

TF-1GLT

E18757
Bi-hex wrench $\text{Ø}10$
Tightening torque 11 Nm

E20870
Tip group

E20888
Change color bushing

TF-1B15

E18757
Bi-hex wrench $\text{Ø}10$
Tightening torque 15 Nm

E20880
Tip group

TF-1B50

E18762
Bi-hex wrench $\text{Ø}10$
Tightening torque 15 Nm

E20868
Tip group

* Gate diameter is approximate and could vary depending on injected volume and part wall thickness.

Injection on sprue

TF-1DSL

E18762
Bi-hex wrench $\text{Ø}10$
Tightening torque 18 Nm

E18840
Tip group

TF17 nozzle



AVAILABLE TIP STYLES ⑤

Injection on sprue

TF-1DSL

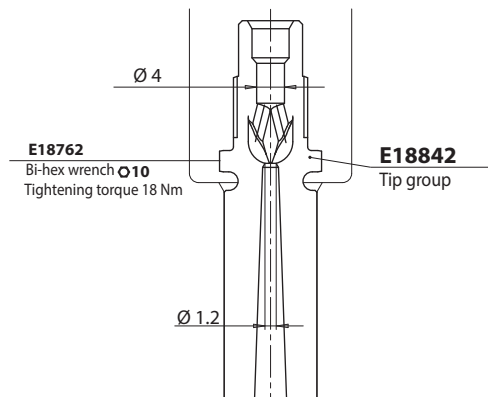
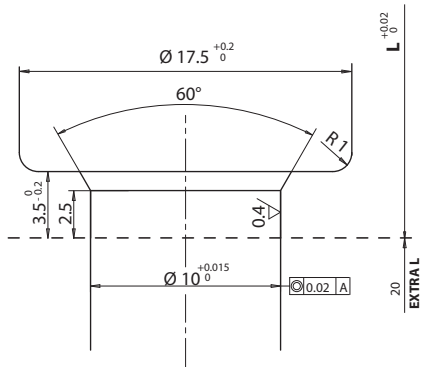
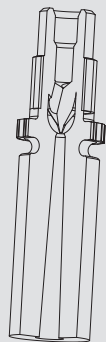

TF-2P

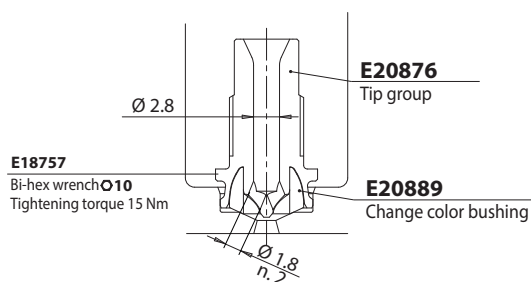
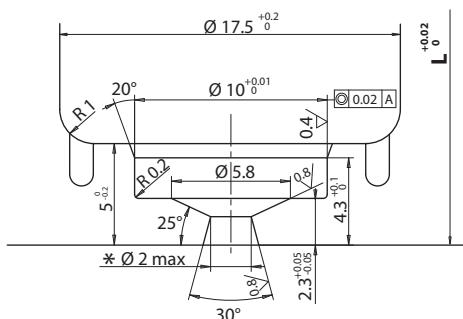

TF-2DSL

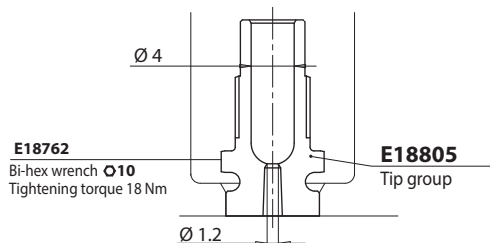
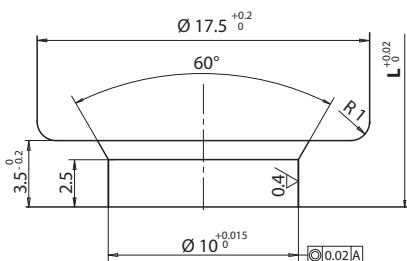
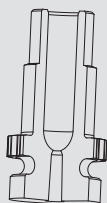

TF-2DSL

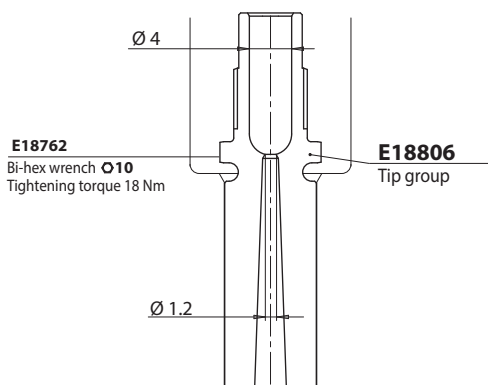
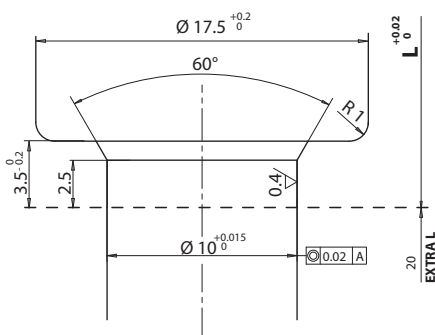
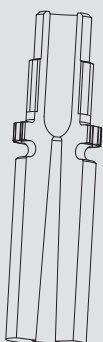

* Gate diameter is approximate and could vary depending on injected volume and part wall thickness.



HEATER AND THERMOCOUPLE WITH WIRE EXIT IN THE TOP

- A ⁴

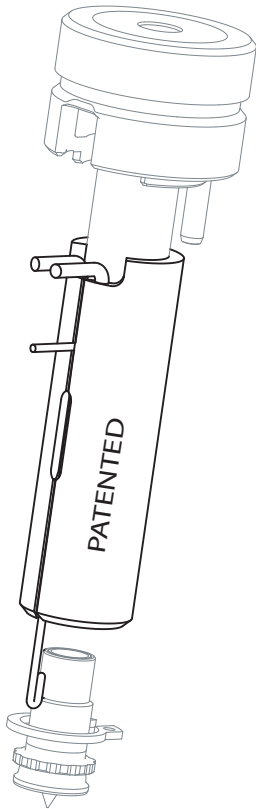

L Nozzle length in mm ^③			Heater P/N	Watt	Thermocouple ^⑥	
1 / 1GLT	1B15	1B50			grounded -JG	insulated -JU
36	37.5	41	E09394	200	E05302	E16027
46	47.5	51	E09395	200		
56	57.5	61	E09310	200		
66	67.5	71	E09311	200		
76	77.5	81	E09312	200		
86	87.5	91	E09313	200	E05504	E16029
96	97.5	101	E09314	200		
106	107.5	111	E09315	200		
116	117.5	121	E09316	200		
126	127.5	131	E09317	200		
136	137.5	141	E09318	220	E05917	E16030
146	147.5	151	E09319	220		
156	157.5	161	E09320	220		
166	167.5	171	E09321	220		
176	177.5	181	E09322	235		
186	187.5	191	E09323	235	E05913	E16031
196	197.5	201	E09324	235		
206	207.5	211	E09325	235		

⑥ .. - JG Grounded thermocouple with J type calibration
 .. - JU Insulated thermocouple with J type calibration

HEATER AND THERMOCOUPLE WITH WIRE EXIT IN THE MIDDLE

- M ⁴

Available only for types: 1/1GLT/1B

The wire exit in the middle of the nozzle body allows the heater replacement with the mould assembled to the injection machine.

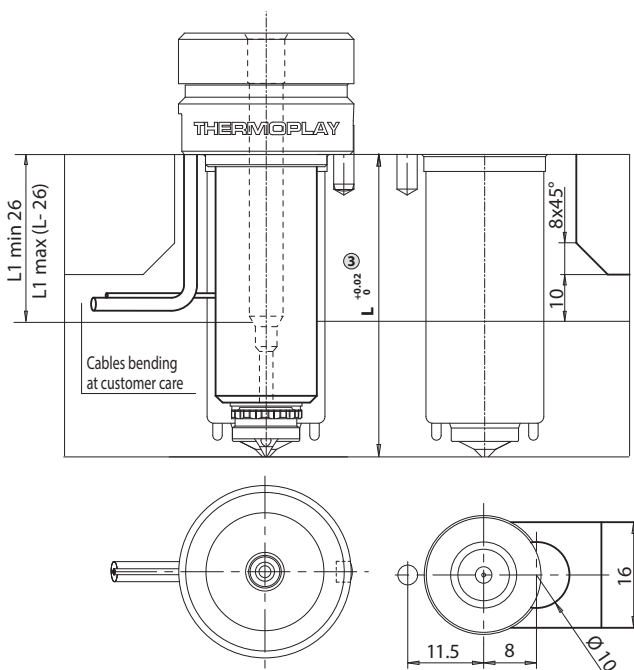

L Nozzle length in mm ^③			Heater P/N	Watt	Thermocouple ^⑥	
1 / 1GLT	1B15	1B50			grounded -JG	insulated -JU
66	67.5	71	E09627	200	E05302	E16027
76	77.5	81	E09628	200		
86	87.5	91	E09629	200		
96	97.5	101	E09630	200	E05504	E16029
106	107.5	111	E09631	200		
116	117.5	121	E09632	200		
126	127.5	131	E09633	200		
136	137.5	141	E09634	220		
146	147.5	151	E09635	220	E05917	E16030
156	157.5	161	E09636	220		
166	167.5	171	E09637	220		
176	177.5	181	E09638	235		
186	187.5	191	E09639	235		
196	197.5	201	E09640	235	E05913	E16031
206	207.5	211	E09641	235		

TF23 nozzle

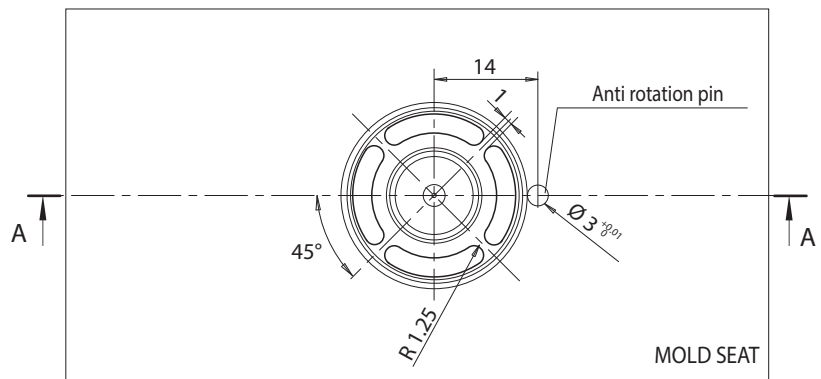
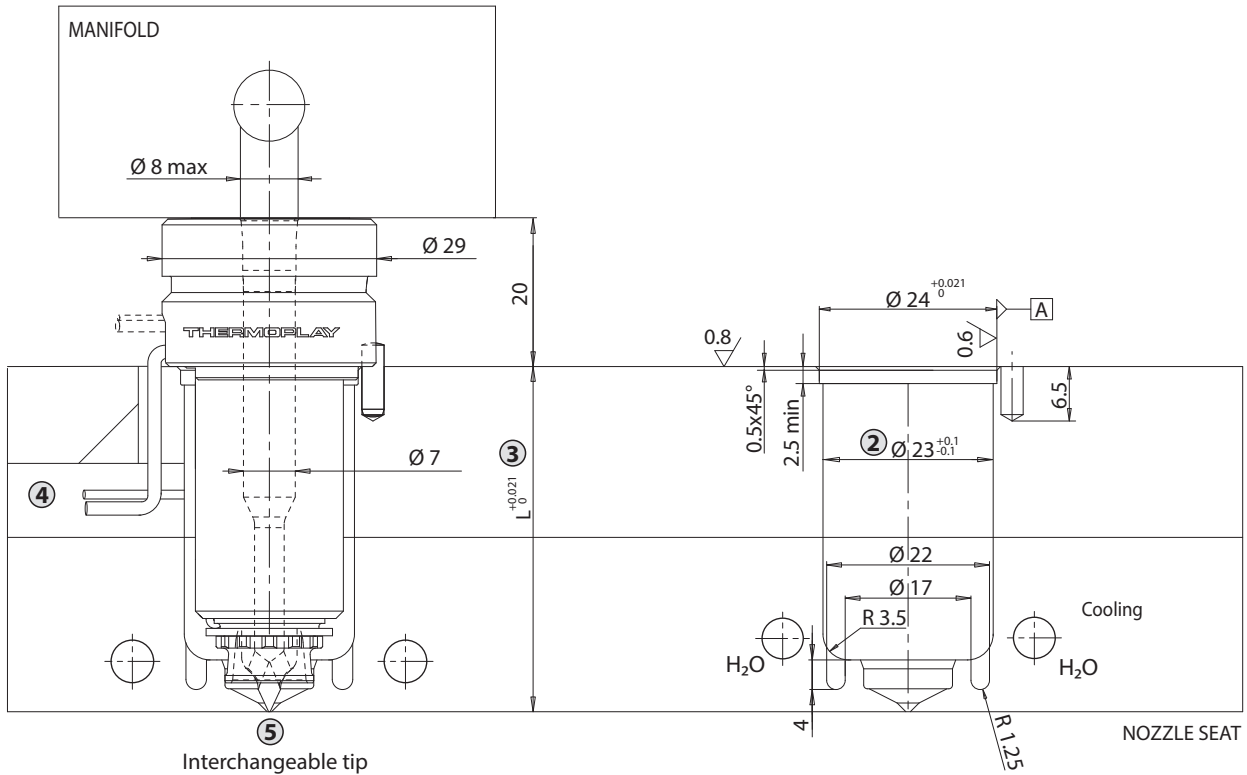

Minimum distance between nozzles centres is available on request

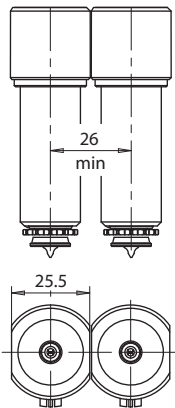

Ordering code example:

①	②	③	④	⑤	⑥
T	F	23	086	-A-	1-JU

- ① TF Nozzle type (TF)
- ② 23 Nozzle diameter in mm (Ø23)
- ③ 086 Nozzle length in mm (L=86)
- ④ A Heater cable exit on top (A= on top / M= middle)
- ⑤ 1 Tip type (1) = see next page for available tip
- ⑥ JU Thermocouple type (JU= insulated / JG= grounded)

* All measures are expressed in mm

TF23 nozzle



AVAILABLE TIP STYLES ⑤

Direct injection

TF-1

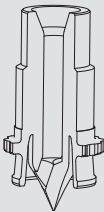
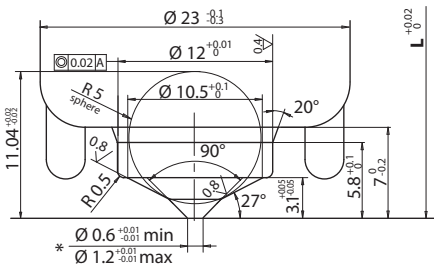
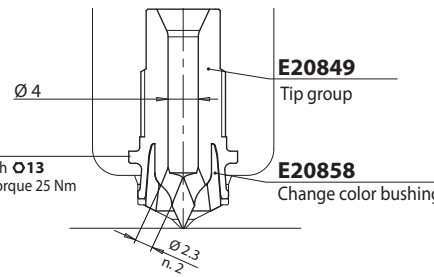



E18758
Bi-hex wrench $\text{Ø}13$
Tightening torque 25 Nm

E20849
Tip group

E20858
Change color bushing

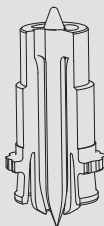
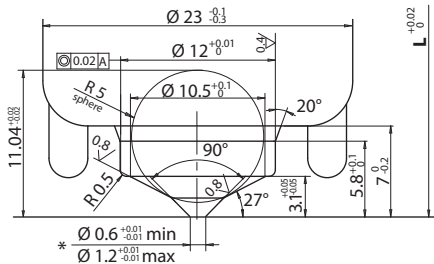
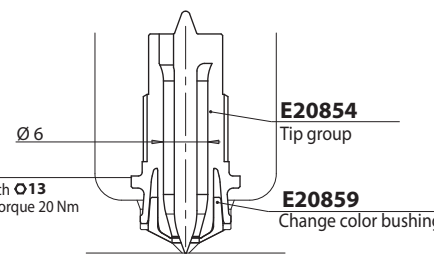
TF-1GLT





E18758
Bi-hex wrench $\text{Ø}13$
Tightening torque 20 Nm

E20854
Tip group

E20859
Change color bushing

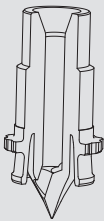
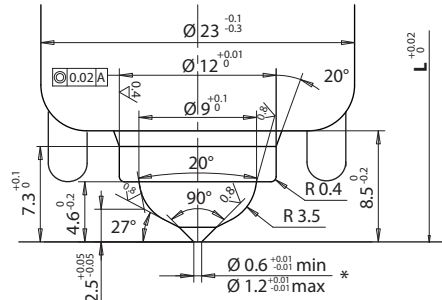
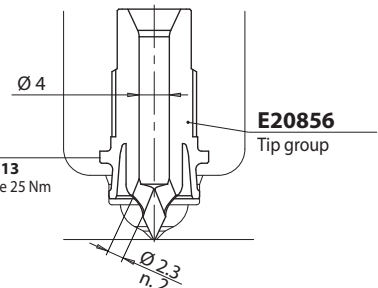
TF-1B15

E18758
Bi-hex wrench $\text{Ø}13$
Tightening torque 25 Nm

E20856
Tip group

TF-1B50

E18763
Bi-hex wrench $\text{Ø}13$
Tightening torque 25 Nm

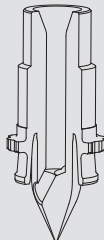
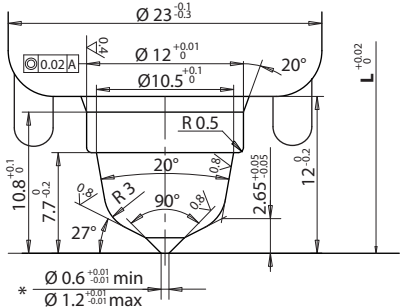
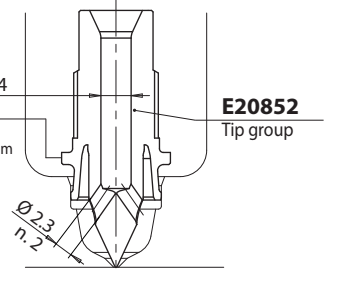
E20852
Tip group

* Gate diameter is approximate and could vary depending on injected volume and part wall thickness.

Injection on sprue

TF-1DSL

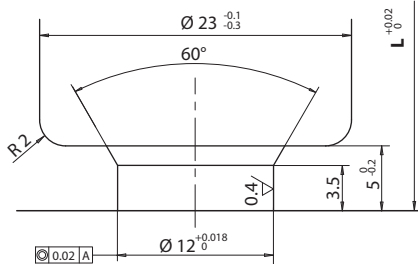
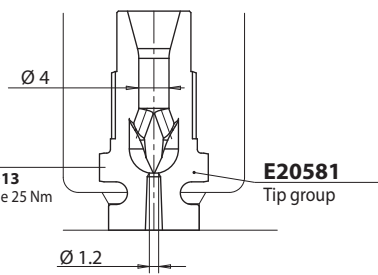
E18763
Bi-hex wrench $\text{Ø}13$
Tightening torque 25 Nm

E20581
Tip group



AVAILABLE TIP STYLES ⑤

Injection on sprue

TF-1DSL

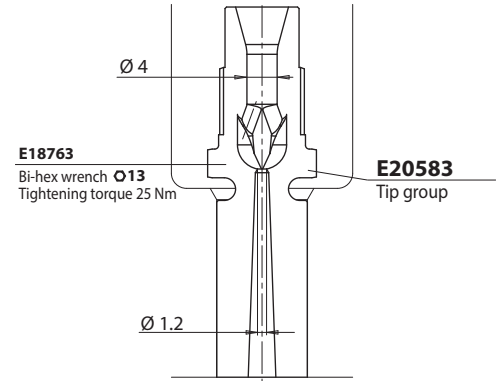
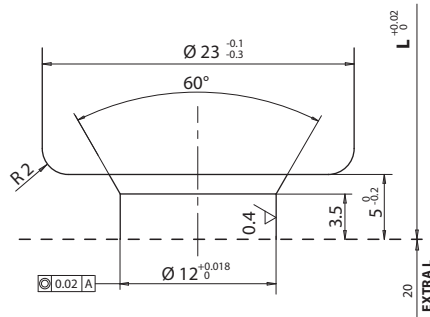
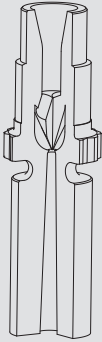

TF-2P

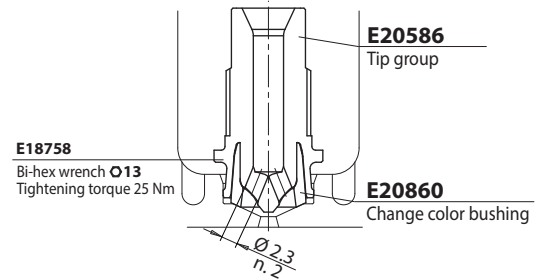
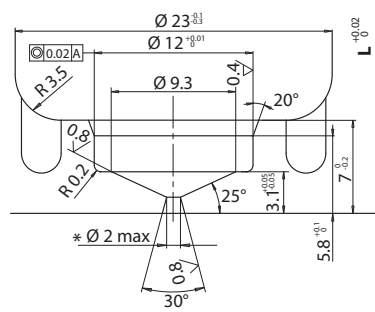
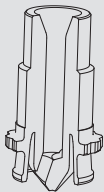

TF-2DSL

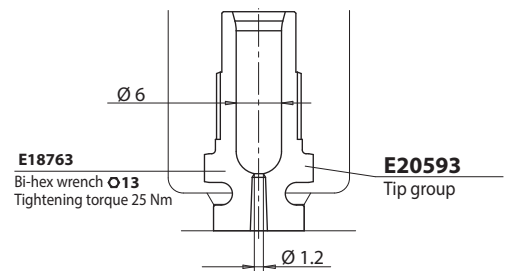
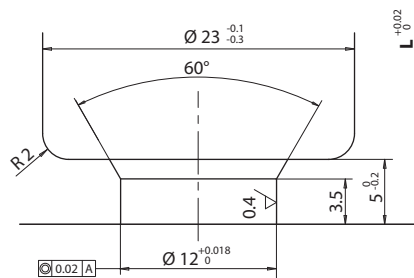
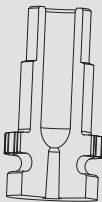

TF-2DSL

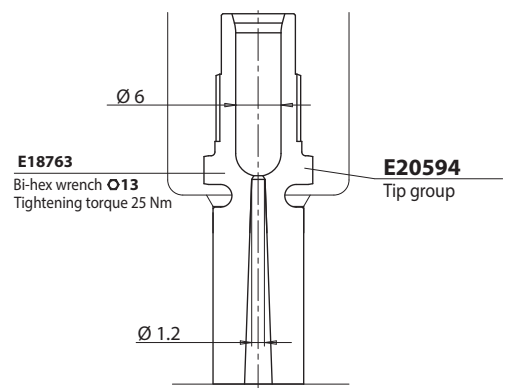
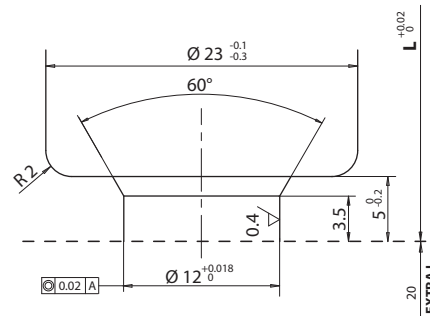
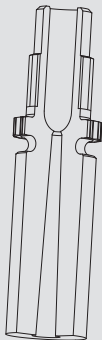

* Gate diameter is approximate and could vary depending on injected volume and part wall thickness.



HEATER AND THERMOCOUPLE WITH WIRE EXIT IN THE TOP

- A ^④

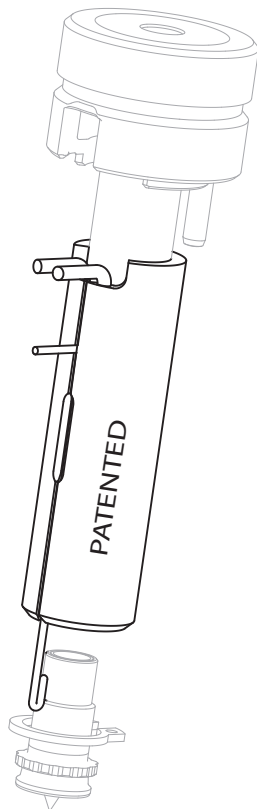

L Nozzle length in mm ^③			Heater P/N	Watt	Thermocouple ^⑥	
1 / 1GLT	1B15	1B50			grounded -JG	insulated -JU
46	47.5	51	E20630	200	E05302	E16027
56	57.5	61	E20631	200		
66	67.5	71	E20632	200		
76	77.5	81	E20633	200	E05504	E16029
86	87.5	91	E20634	200		
96	97.5	101	E20635	250		
106	107.5	111	E20636	250		
116	117.5	121	E20637	250	E05917	E16030
126	127.5	131	E20638	250		
136	137.5	141	E20639	270		
146	147.5	151	E20640	270		
156	157.5	161	E20641	300		
166	167.5	171	E20642	300	E05913	E16031
176	177.5	181	E20643	350		
186	187.5	191	E20644	350		
196	197.5	201	E20645	350		
206	207.5	211	E20646	350		

⑥ .. - JG Grounded thermocouple with J type calibration
 .. - JU Insulated thermocouple with J type calibration

HEATER AND THERMOCOUPLE WITH WIRE EXIT IN THE MIDDLE

- M ^④

Available only for types: 1/1GLT/1B

The wire exit in the middle of the nozzle body allows the heater replacement with the mould assembled to the injection machine.

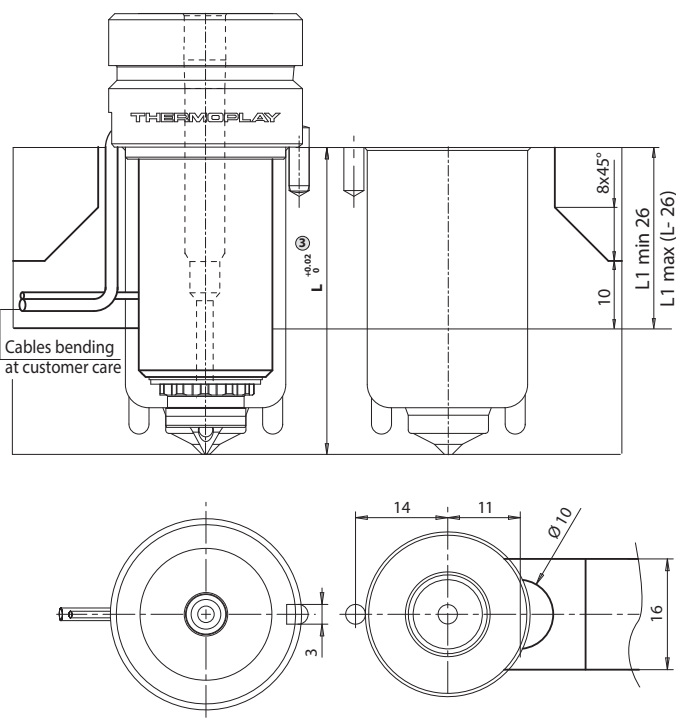

L Nozzle length in mm ^③			Heater P/N	Watt	Thermocouple ^⑥	
1 / 1GLT	1B15	1B50			grounded -JG	insulated -JU
66	67.5	71	E21107	200	E05302	E16027
76	77.5	81	E20108	200		
86	87.5	91	E20109	200		
96	97.5	101	E21110	250	E05504	E16029
106	107.5	111	E21111	250		
116	117.5	121	E21112	250		
126	127.5	131	E21113	250		
136	137.5	141	E21114	270	E05917	E16030
146	147.5	151	E21115	270		
156	157.5	161	E21116	300		
166	167.5	171	E21117	300		
176	177.5	181	E21118	350		
186	187.5	191	E21119	350	E05913	E16031
196	197.5	201	E21120	350		
206	207.5	211	E21121	350		

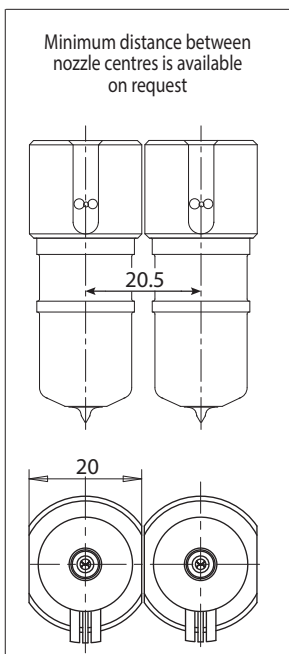
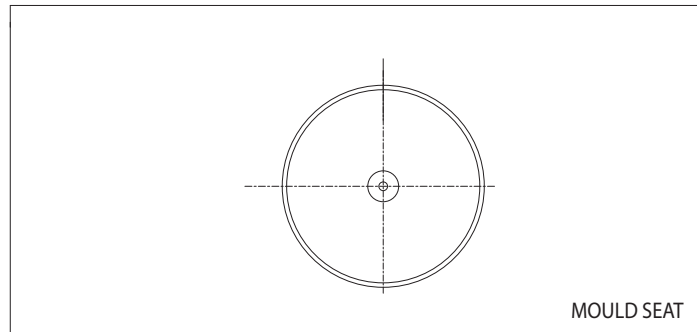
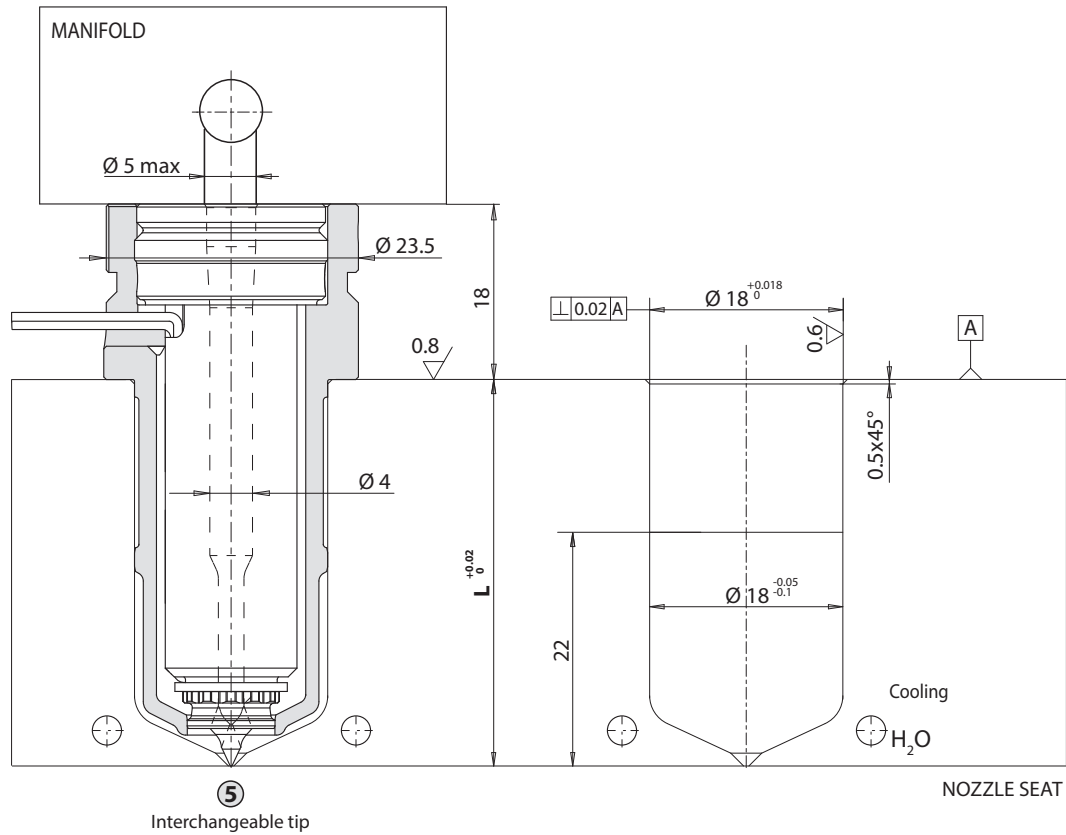

Ordering code example:

①
②
③
⑤
⑥
T
D
1
8
0
8
6
-
1
-
J
U

- ① TD Nozzle type (TD)
- ② 18 Nozzle diameter in mm (Ø18)
- ③ 086 Nozzle length in mm (L=86)
- ④ A Heater cable exit on top (A= on top)
- ⑤ 1 Tip type (1) = see next page for available tip
- ⑥ JU Thermocouple type (JU= insulated / JG= grounded)

* All measures are expressed in mm



AVAILABLE TIP STYLES ⑤

Direct injection

TD-1

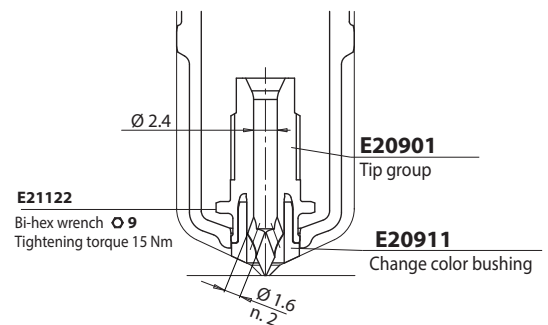
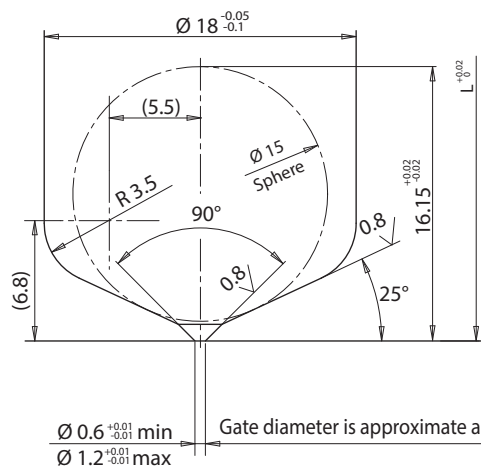
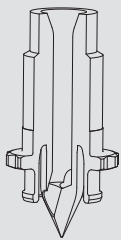

Gate diameter is approximate and could vary depending on injected volume and part wall thickness.

TD-1B35

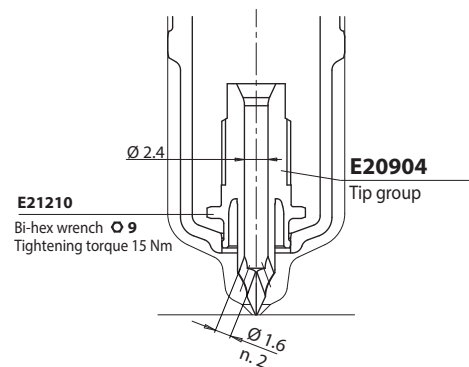
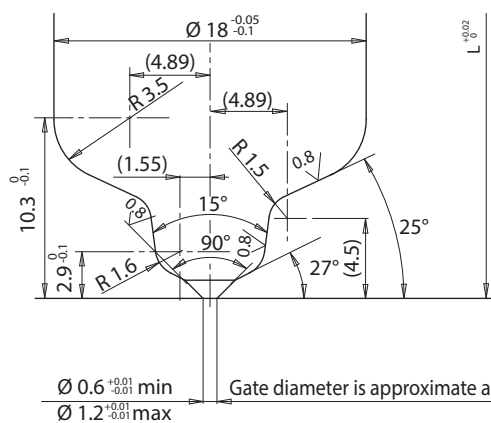
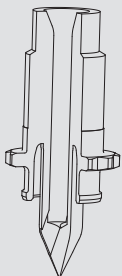

Gate diameter is approximate and could vary depending on injected volume and part wall thickness.



HEATER AND THERMOCOUPLE

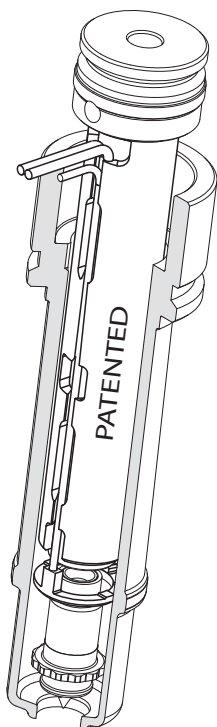

L Nozzle length in mm ^③		Heater code P/N	Watt	Thermocouple	
1	1B35			grounded -JG	insulated -JU
36	39.5	E16853	160	E20952	E20956
46	49.5	E16854	180		
56	59.5	E16855	180		
66	69.5	E16856	180		
76	79.5	E16857	200		
86	89.5	E16858	200	E20953	E20957
96	99.5	E16859	200		
106	109.5	E16860	200		
116	119.5	E16861	200		
126	129.5	E16862	230	E20954	E20958
136	139.5	E16863	230		
146	149.5	E16864	230		

- ⑥ .. - **JG** Grounded thermocouple with J type calibration
 ⑥ .. - **JU** Insulated thermocouple with J type calibration

Suffix ^⑥	Description
.. - JG	Grounded thermocouple with J type calibration
.. - JU	Insulated thermocouple with J type calibration

Cables	HEATER	
	White / Red-White	230 V
	THERMOCOUPLE	
	Red	TC+
Blu	TC-	

Ordering code example:

① ② ③ ⑤ ⑥
T D 1 8 0 8 6 - 1 - J U

- ① TD nozzle type (TD)
- ② 18 Nozzle diameter in mm (Ø18)
- ③ 086 Nozzle length in mm (L=086)
- ⑤ 1 Tip type (1)
- ⑥ JU Thermocouple type (JU= insulated / JG= grounded)

If not specified, grounded thermocouple are supplied

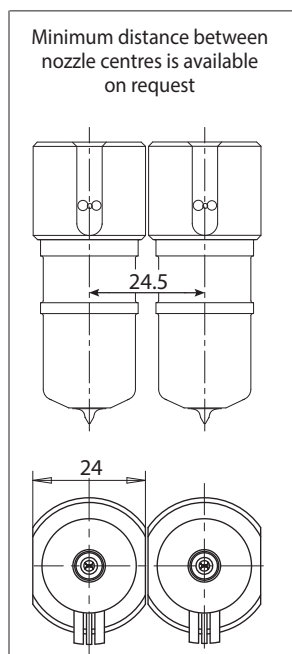
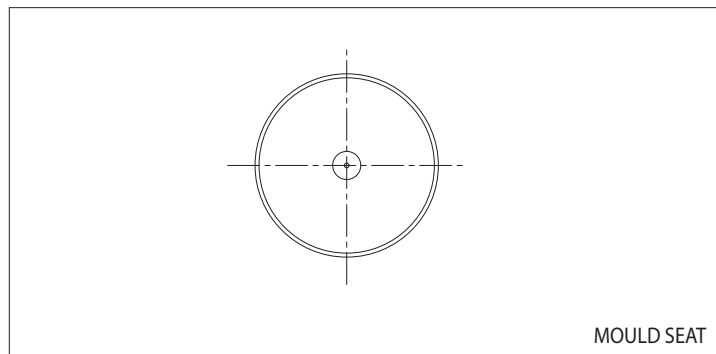
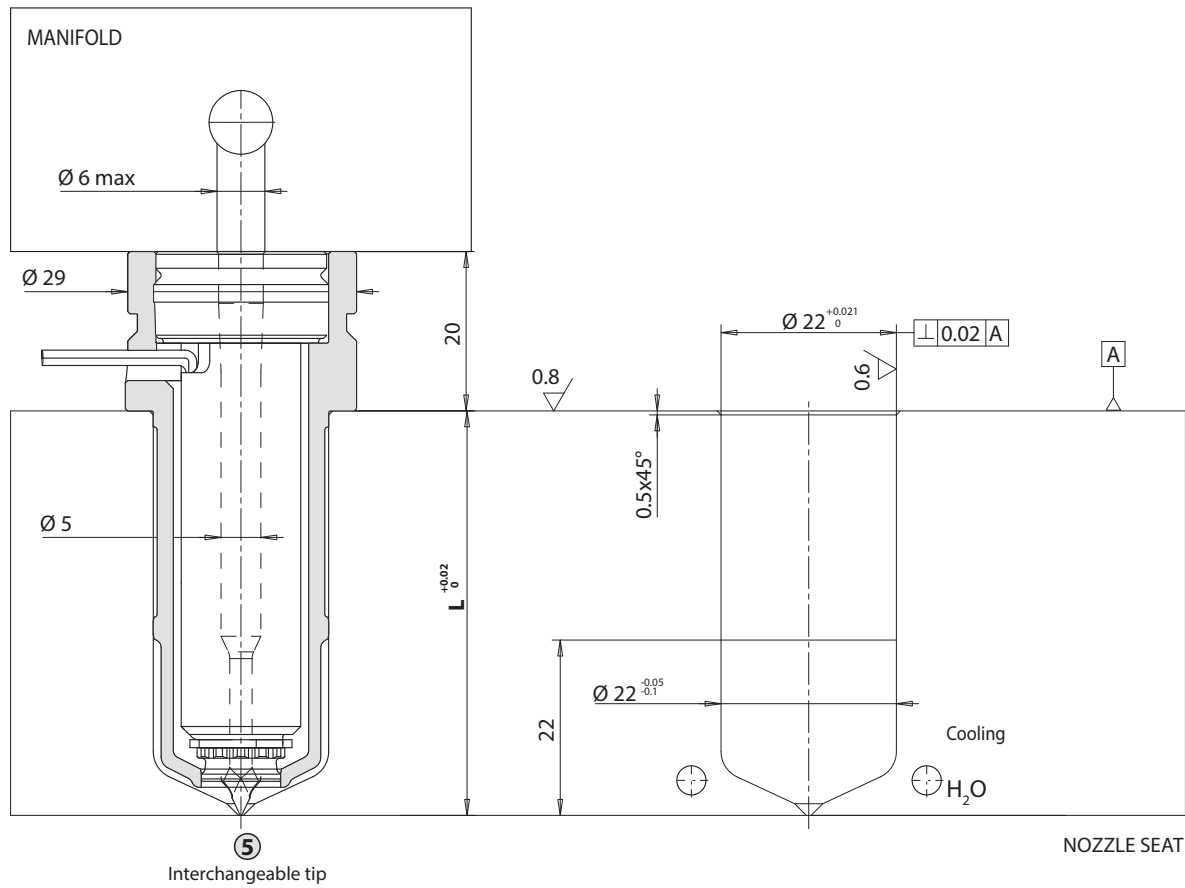

Ordering code example:

① ② ③ ⑤ ⑥

T D 2 2 0 8 6 - 1 - J U

- ① TD Nozzle type (TD)
- ② 22 Nozzle diameter in mm (Ø22)
- ③ 086 Nozzle length in mm (L=86)
- ⑤ 1 Tip type (1) = see next page for available tip
- ⑥ JU Thermocouple type (JU= insulated / JG= grounded)

TD22 nozzle



AVAILABLE TIP STYLES ⑤

Direct injection

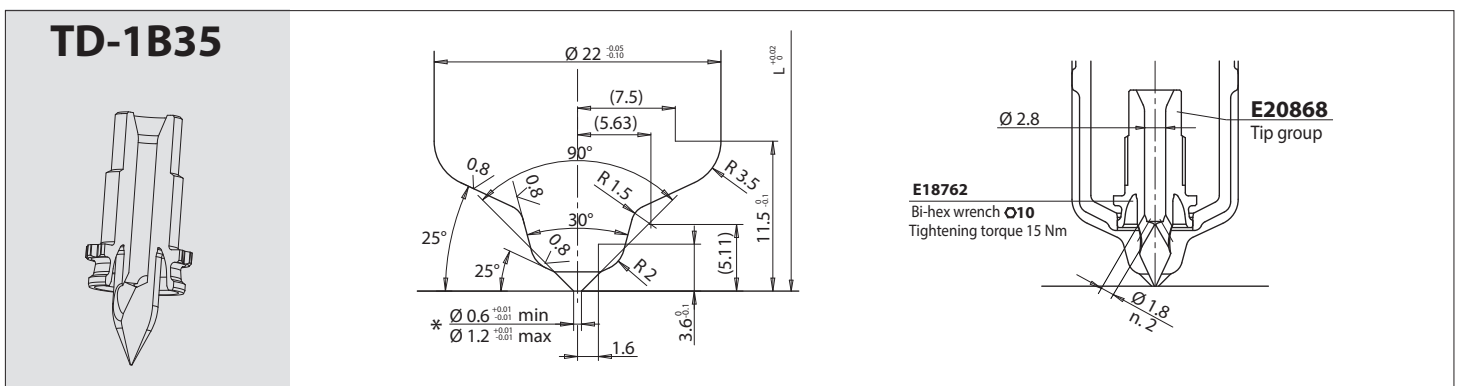
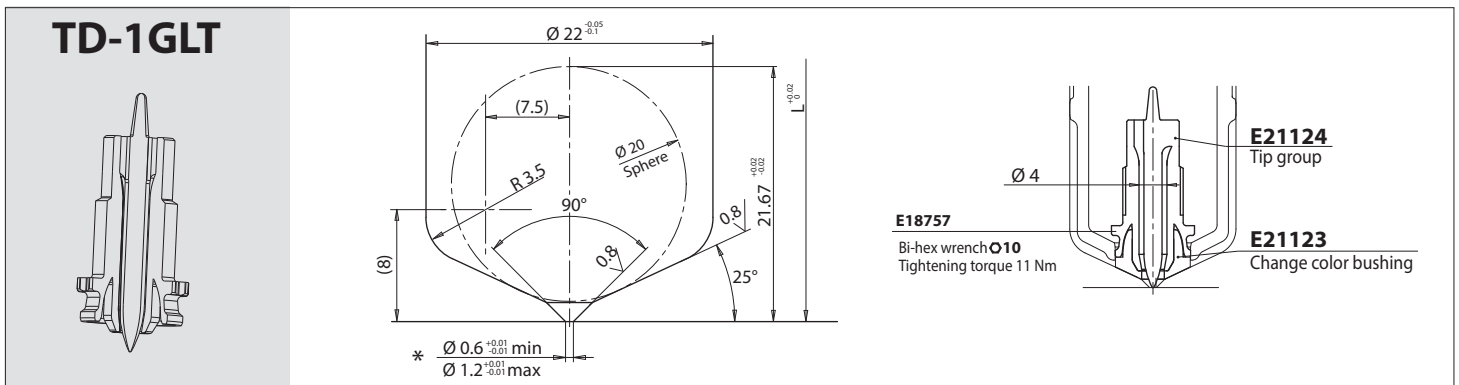
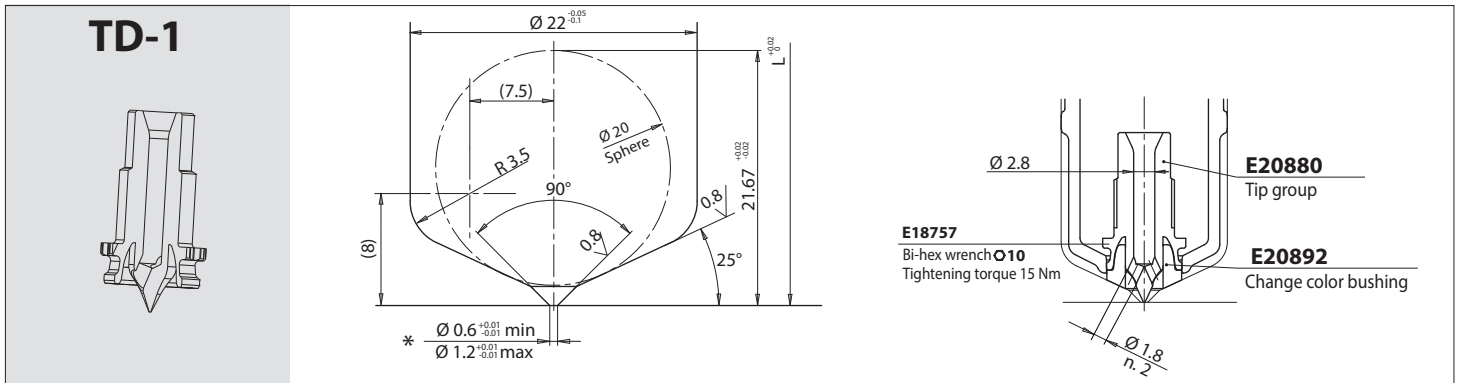

* Gate diameter is approximate and could vary depending on injected volume and part wall thickness.



HEATER AND THERMOCOUPLE

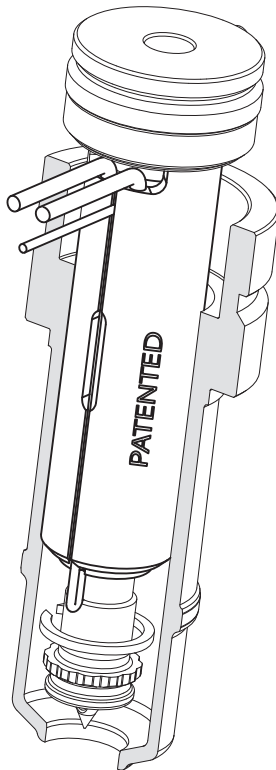

L Nozzle length in mm ^③		Heater code P/N	Watt	Thermocouple	
1	1B35			grounded -JG	insulated -JU
36	39.5	E09394	200	E05302	E16027
46	49.5	E09395	200		
56	59.5	E09310	200		
66	69.5	E09311	200		
76	79.5	E09312	200		
86	89.5	E09313	200	E05504	E16029
96	99.5	E09314	200		
106	109.5	E09315	200		
116	119.5	E09316	200		
126	129.5	E09317	200		
136	139.5	E09318	220	E05917	E16030
146	149.5	E09319	220		

- ⑥ .. - **JG** Grounded thermocouple with J type calibration
 ⑥ .. - **JU** Insulated thermocouple with J type calibration

Suffix ^⑥	Description
.. - JG	Grounded thermocouple with J type calibration
.. - JU	Insulated thermocouple with J type calibration

Cables	HEATER	
	White / Red-White	230 V
	THERMOCOUPLE	
	Red	TC+
Blue	TC-	

Ordering code example:



- ① **TD** Nozzle type (TD)
 ② **22** Nozzle diameter in mm (Ø22)
 ③ **086** Nozzle length in mm (L=086)
 ⑤ **1** Tip type (1)
 ⑥ **JU** Thermocouple type (JU= insulated / JG= grounded)

If not specified, grounded thermocouple are supplied

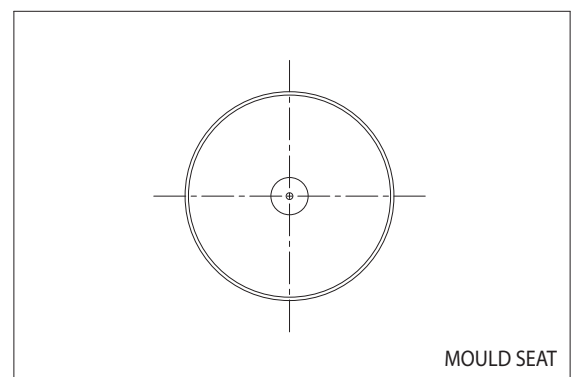
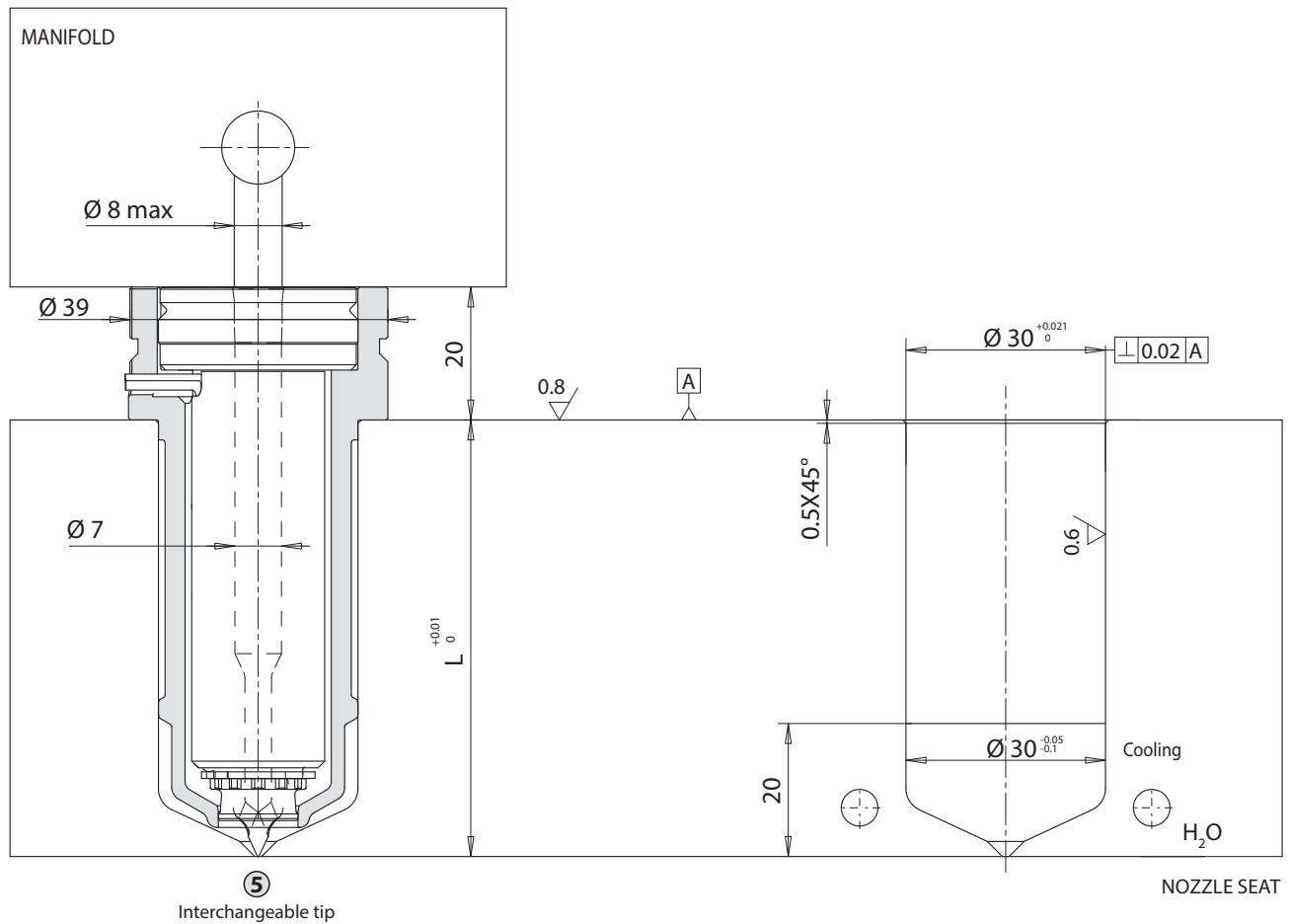

Ordering code example:

①
②
③
⑤
⑥
T
D
3
0
0
8
6
-
1
-
J
U

- ① TD Nozzle type (TD)
- ② 30 Nozzle diameter in mm (Ø30)
- ③ 086 Nozzle length in mm (L=086)
- ⑤ 1 Tip type (1)
- ⑥ JU Thermocouple type (JU= insulated / JG= grounded)



Direct injection

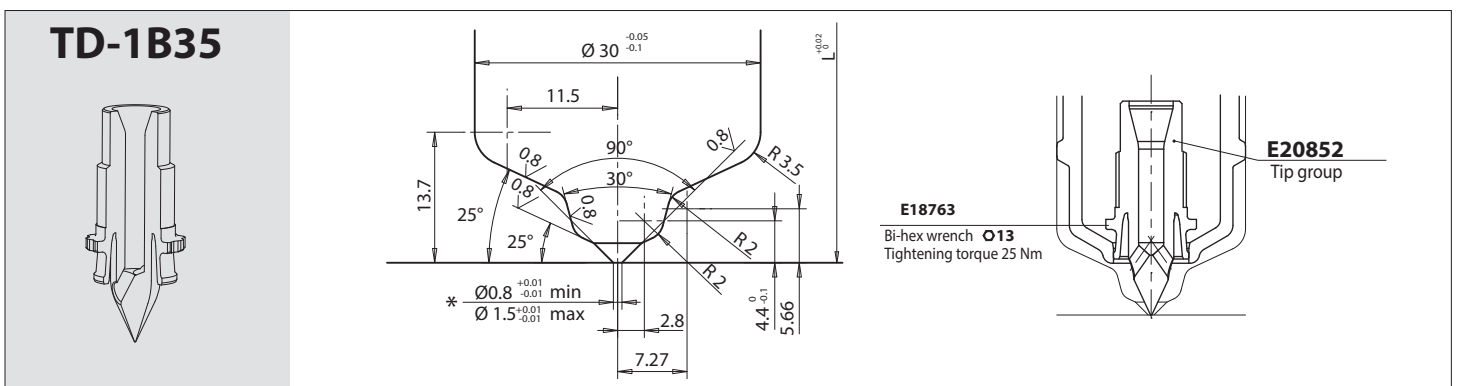
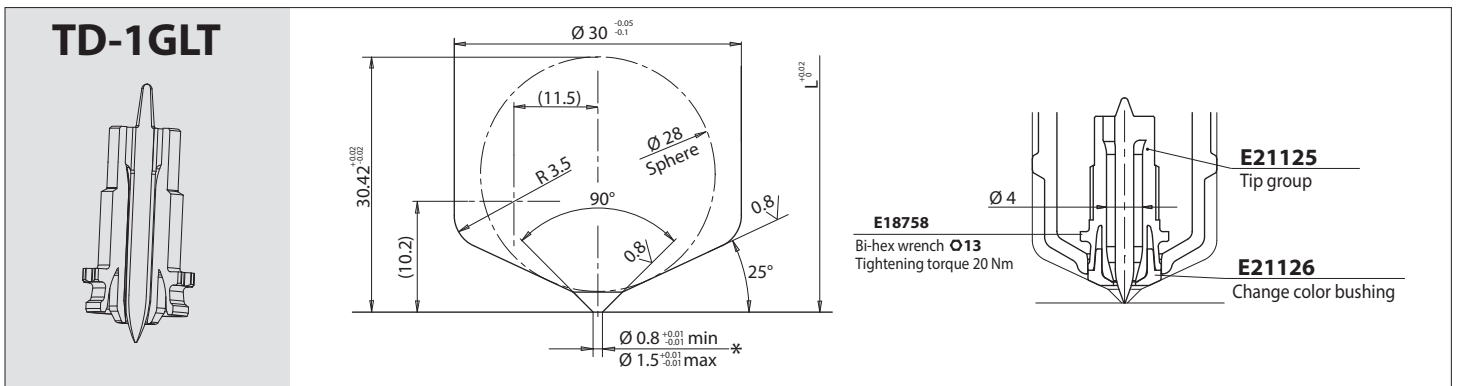
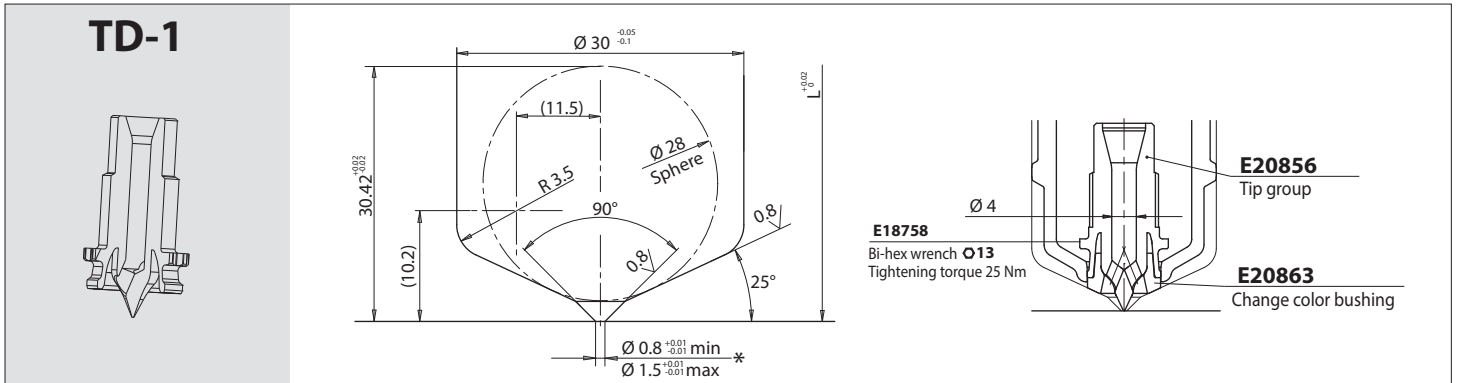

* Gate diameter is approximate and could vary depending on injected volume and part wall thickness.



HEATER AND THERMOCOUPLE

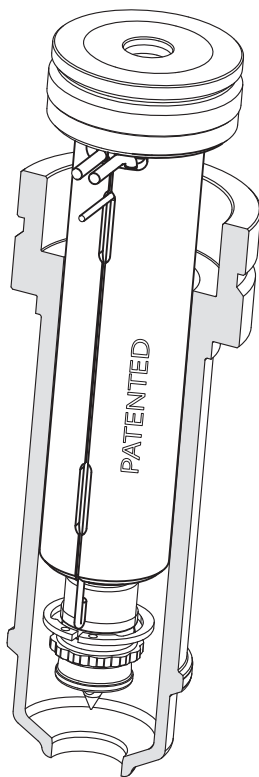

L Nozzle length in mm		Heater code P/N	Watt	Thermocouple	
1	1B35			grounded -JG	insulated -JU
46	49.5	E20630	200	E05302	E16027
56	59.5	E20631	200		
66	69.5	E20632	200		
76	79.5	E20633	200		
86	89.5	E20634	200	E05504	E16029
96	99.5	E20635	250		
106	109.5	E20636	250		
116	119.5	E20637	250		
126	129.5	E20638	250	E05917	E16030
136	139.5	E20639	270		
146	149.5	E20640	270		

- ⑥ .. - **JG** Grounded thermocouple with J type calibration
 .. - **JU** Insulated thermocouple with J type calibration

Suffix ⑥	Description
.. - JG	Grounded thermocouple with J type calibration
.. - JU	Insulated thermocouple with J type calibration

Cables	HEATER	
	White / Red-White	230 V
	THERMOCOUPLE	
	Red	TC+
Blue	TC-	

Ordering code example:

① ② ③ ⑤ ⑥
T D 3 0 0 8 6 - 1 - J U

- ① **TD** Nozzle type (TD)
- ② **30** Nozzle diameter in mm (Ø30)
- ③ **086** Nozzle length in mm (L=086)
- ⑤ **1** Tip type (1)
- ⑥ **JU** Thermocouple type (JU= insulated / JG= grounded)

If not specified, grounded thermocouple are supplied



AVAILABLE BUSHING STYLES

SEALING BUSHING

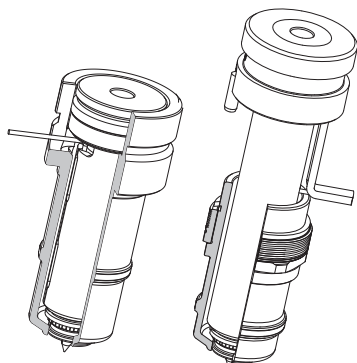

WEAR RESISTANT BUSHING

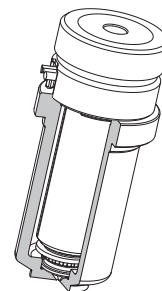

COOLING BUSHING

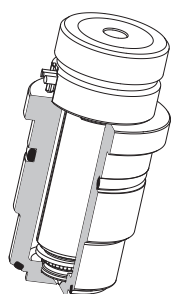

COLOR CHANGE BUSHING

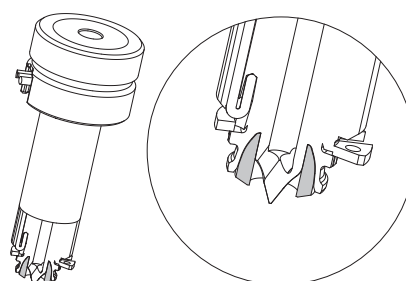

Tip type	Name Ø	Sealing bushing	Cooling bushing	Color change bushing	Wear resistant bushing
1	TF 12	✗	✗	✗	✗
	TF 17	✓	✓	✓	✓
	TD 18	✓	✓	✓	✗
	TD 22	✓	✓	✓	✗
	TF 23	✓	✓	✓	✓
	TD 30	✓	✓	✓	✗
1B15	TF 17	✗	✗	✗	✗
	TF 23	✗	✗	✗	✗
1B35	TD 18	✓	✗	✗	✗
	TD 22	✓	✗	✗	✗
	TD 30	✓	✗	✗	✗
1B50	TF 17	✗	✗	✗	✗
	TF 23	✗	✗	✗	✗
1GLT	TF 17	✓	✓	✓	✓
	TD 22	✓	✓	✓	✓
	TF 23	✓	✓	✓	✓
	TD 30	✓	✓	✓	✗
1DSLA	TF 17	✗	✗	✗	✗
	TF 23	✗	✗	✗	✗
1DSLX	TF 17	✗	✗	✗	✗
	TF 23	✗	✗	✗	✗
2P	TF 17	✗	✓	✓	✓
	TF 23	✗	✓	✓	✓
2DSLA	TF 17	✗	✗	✗	✗
	TF 23	✗	✗	✗	✗
2DSLX	TF 17	✗	✗	✗	✗
	TF 23	✗	✗	✗	✗



STANDARD DESIGN OF THERMOPLAY HOT HALF

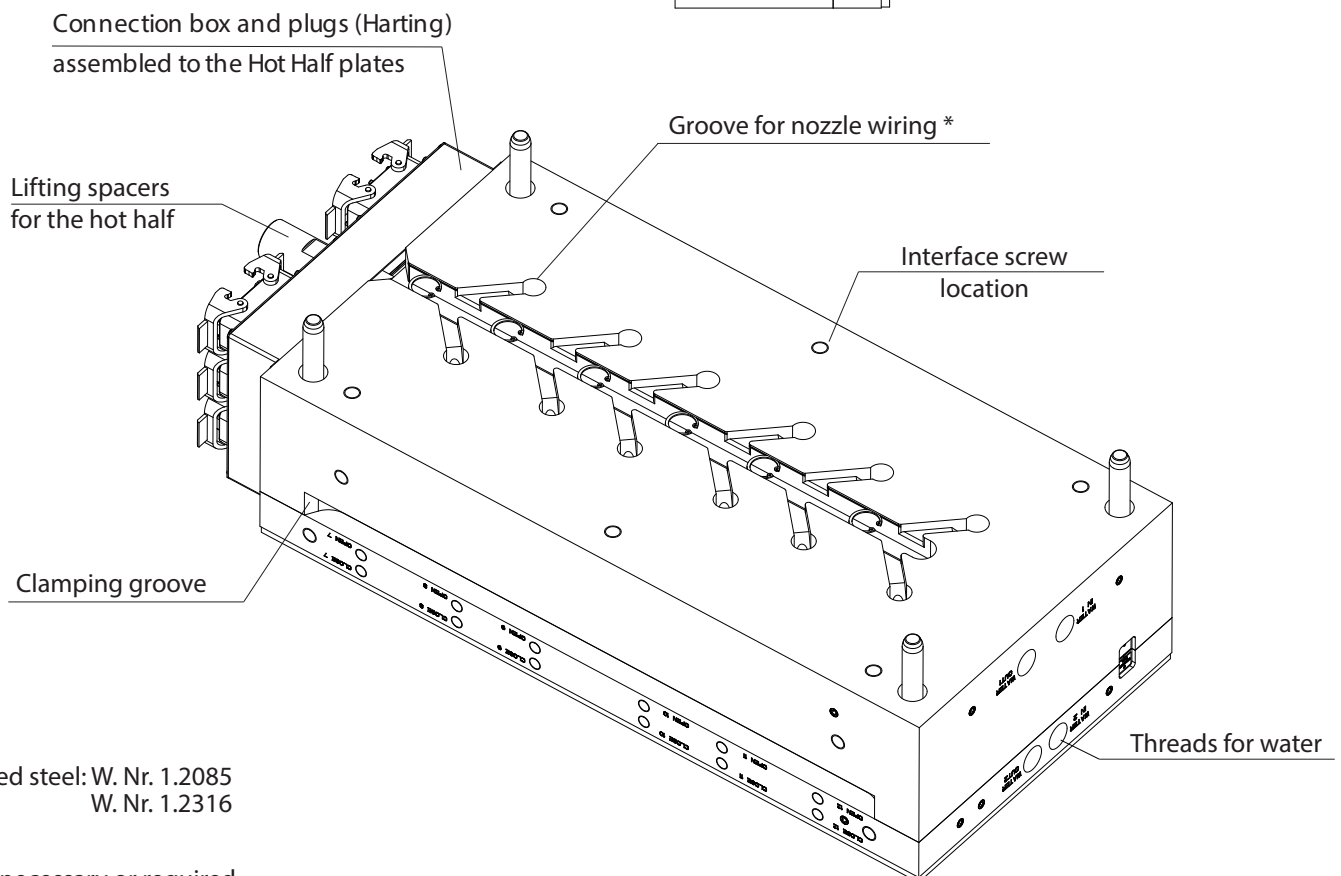
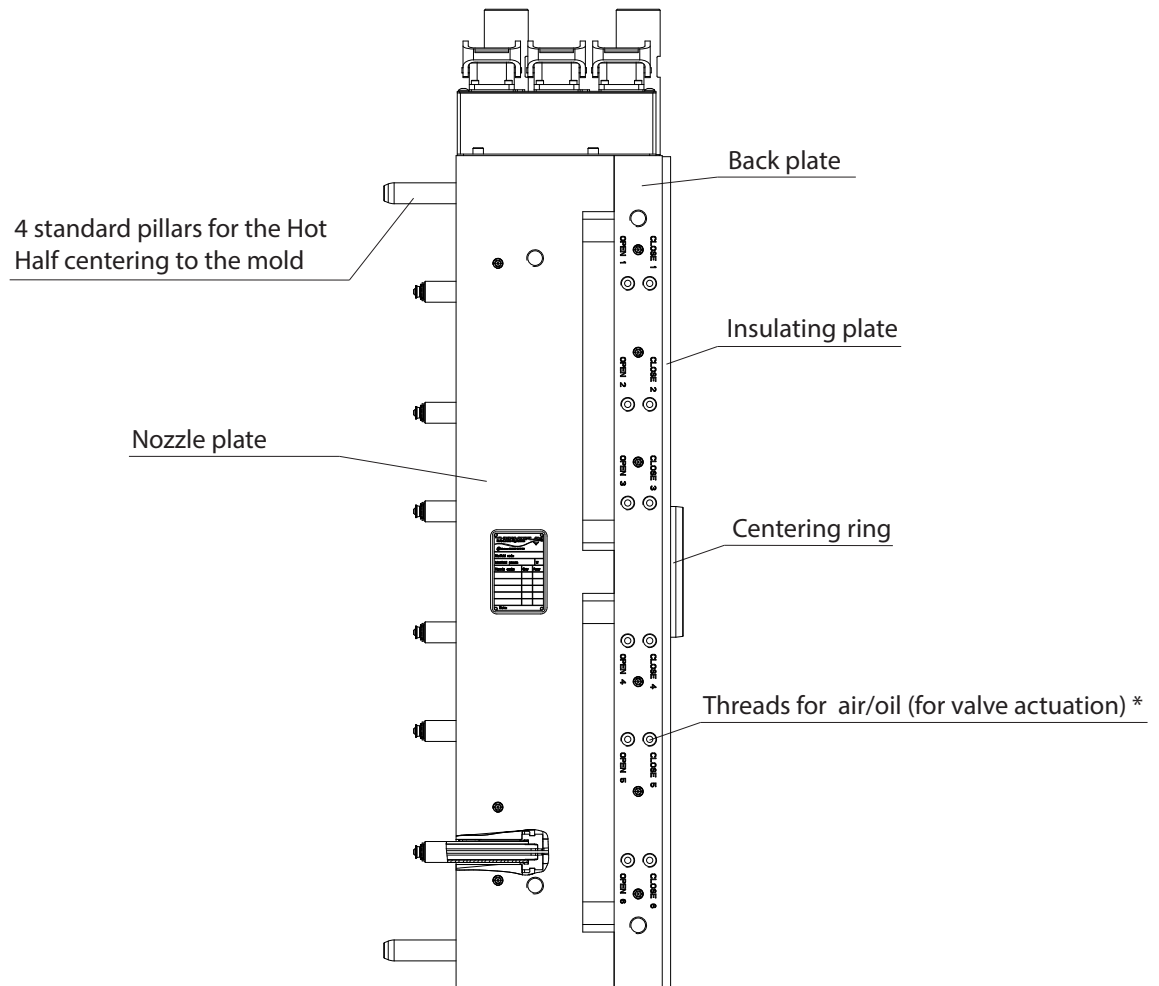

Used steel: W. Nr. 1.2085
W. Nr. 1.2316

* If necessary or required

Any difference from our standard Hot Half Thermoplay will cause a revision of our quotation with an increase of price



HOT HALF WITH 16 DROPS

Nozzles: TFØ23

Tip style: 1

Nozzle length: 66 mm

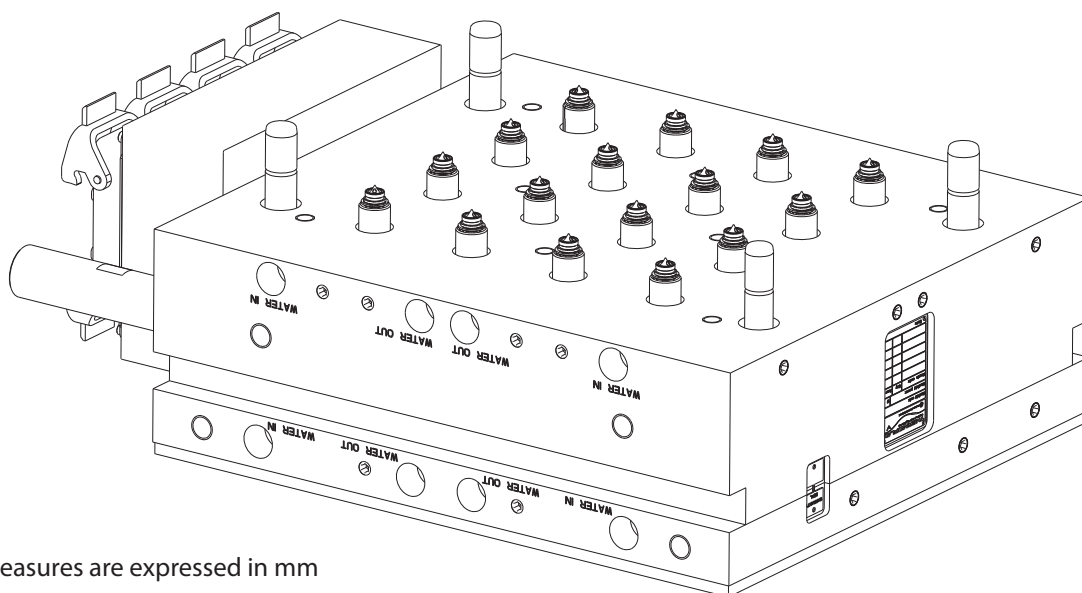
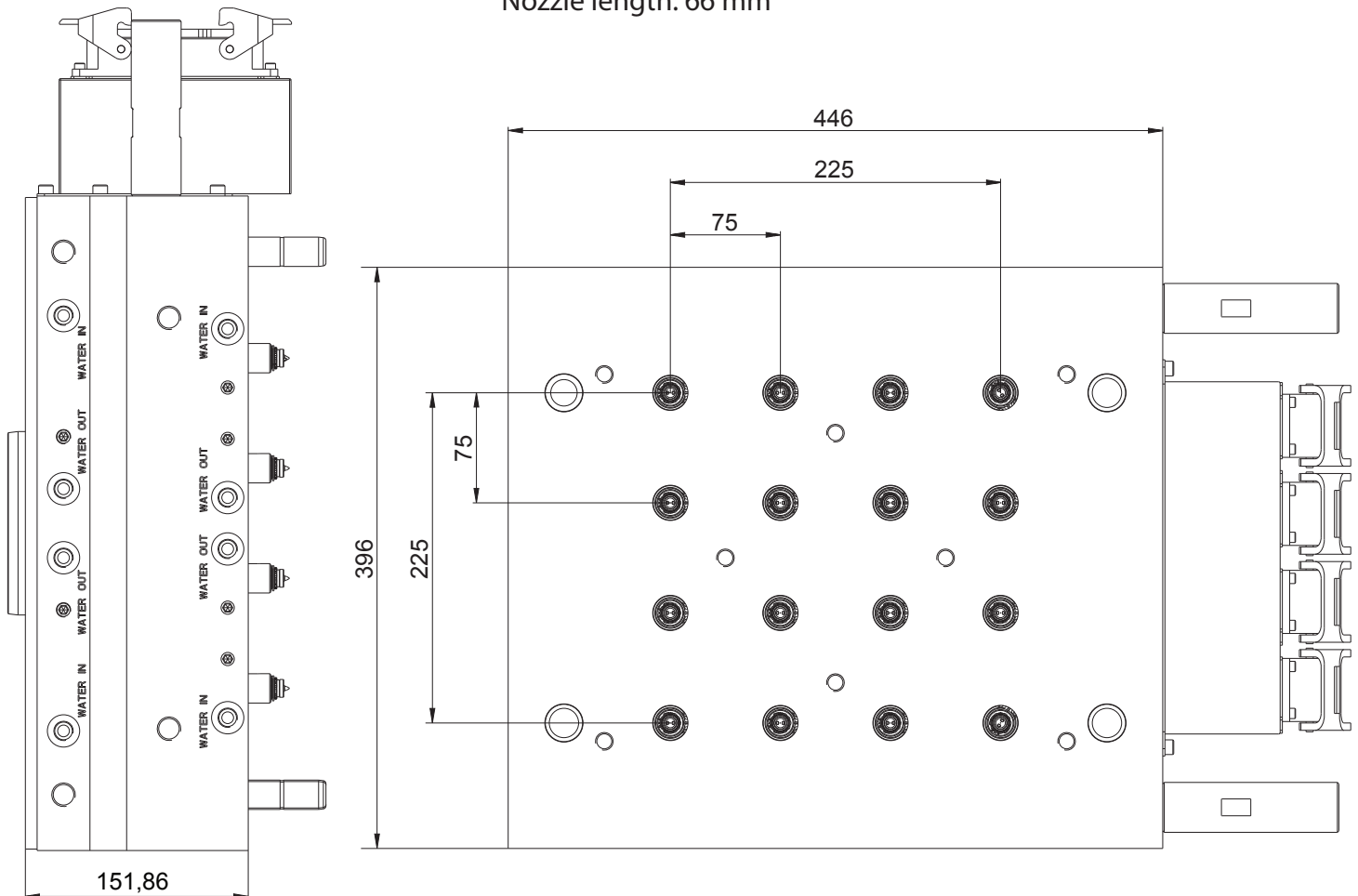

* All measures are expressed in mm



HOT HALF WITH 32 DROPS

Nozzles: TFØ17
Tip style: 1
Nozzle length: 106 mm

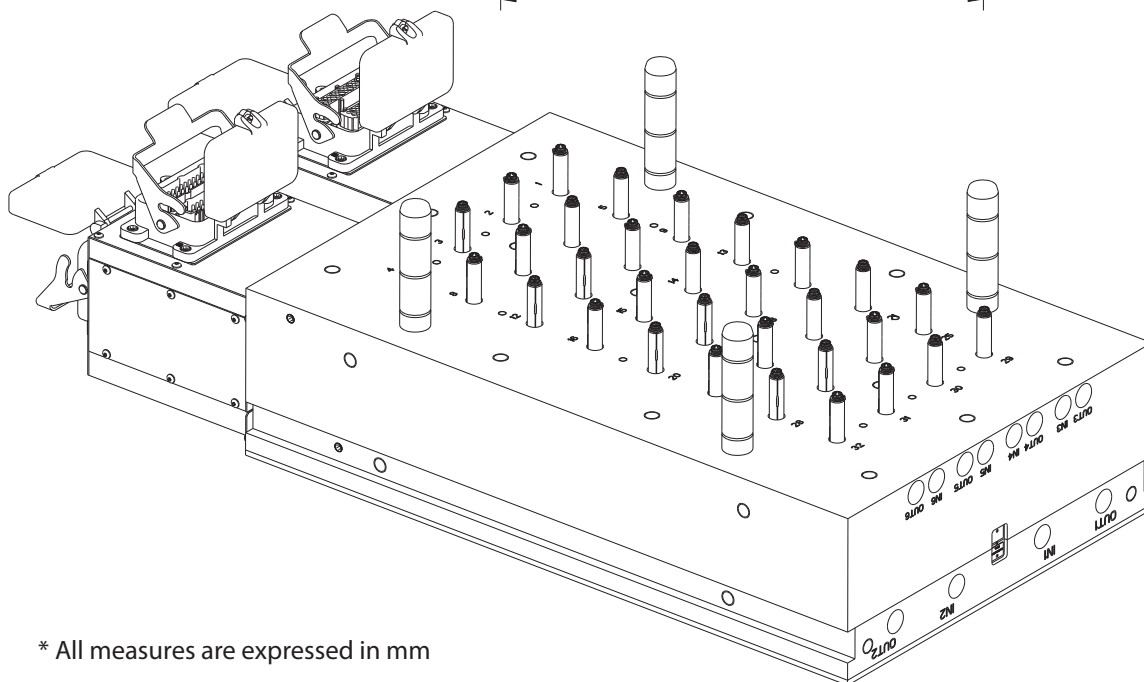
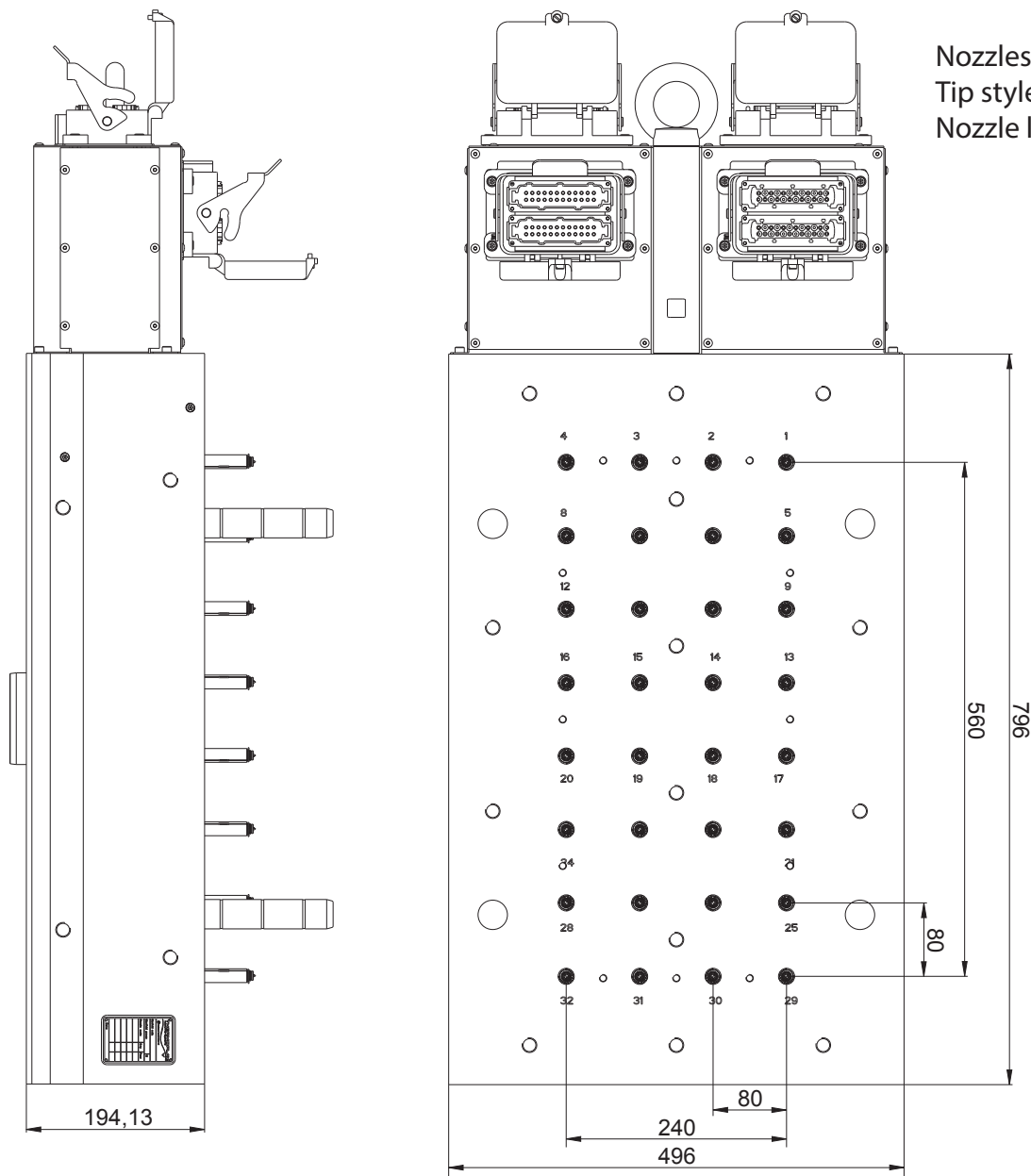

* All measures are expressed in mm



HOT HALF WITH 64 DROPS

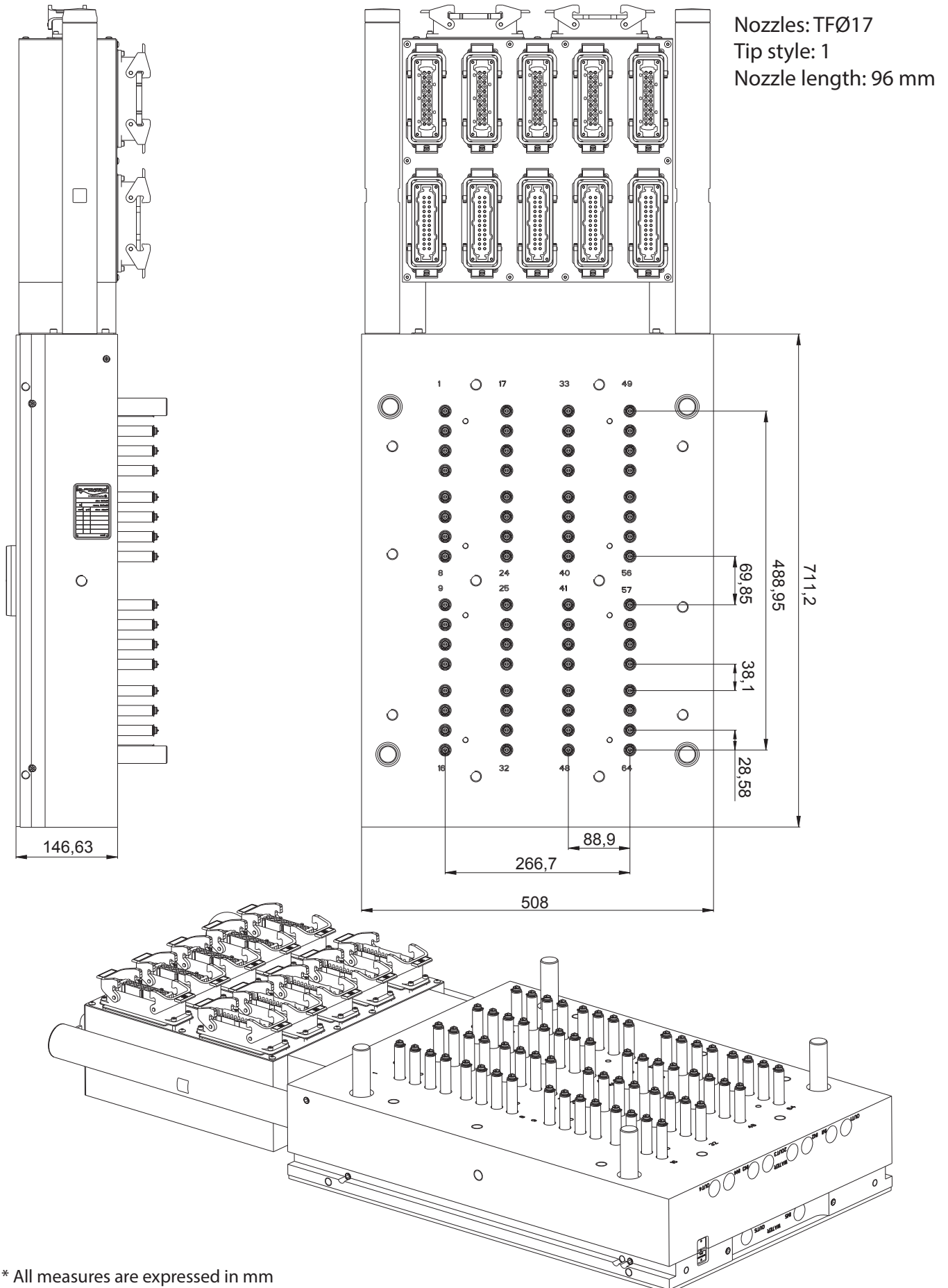

* All measures are expressed in mm



Network

ITALY

Torino, Asti, Vercelli, Cuneo, Biella: THERMOPLAY S.p.A. - ANTONIO DE LONGHI - Via Carlo Viola 74 11026, Pont-Saint-Martin (TO) T. +39 3409737303 - a.delonghi@thermoplay.com
Aosta, Alessandria, Liguria: THERMOPLAY S.p.A. - Via Carlo Viola 74 - 11026 Pont Saint Martin (AO) T. +39 340 9737303 - thermoplay@thermoplay.com
Milano ovest, Novara, Verbanco-Cusio-Ossola, Sondrio, Varese, Como, Pavia, Lodi, Cremona e prov.: THERMOPLAY S.p.A. - GIANLUCA MOZZATO - Via Carlo Viola 74 11026, Pont Saint-Martin (AO) T. +39 349 2285336 - g.mozzato@thermoplay.com
Milano nord, sud, est, Monza Brianza, Lecco e prov.: GALLINO PLASTICS s.a.s. Via dei Mille 9 - 24047, Treviglio (BG) - Tel. +39 0363 1842179 - Cell. +39 348 4464000 - info@galmax.com
Bergamo, Brescia, Mantova, Veneto, Trentino, Friuli Venezia Giulia, Emilia Romagna: AGENTS srl, Via Dante Alighieri - 36075 Montecchio Maggiore (VI) - T +39 348 4461254 - ufficio@agents.it
Toscana, Umbria: ROBERTO MUGNAINI - Via Chini, 3 - 50051 Castelflorentino (FI) - T. +39 335 1039473 - rmugn@tin.it
Marche, Abruzzo, Molise: TECNOUTENSILI srl - Via Abbadia, 18 - 60021 Camerano (AN) - T. +39 071 7300016 - info@tecnoutensili.it
Lazio: SMEN s.a.s. - Via Messico, 17/B - 00040 Pomezia (Rm) - T. +39 06 9107027 - info@smen.it
Campania: LA MARCA srl - Via Variante 7/bis km 45,150 - 80030 Mariglianella (NA) - T. +39 081 8411555 - info@lamarcagroup.it

EUROPE

AUSTRIA: THERMOPLAY DEUTSCHLAND GmbH - Hoffmeisterstrasse, 15 - D 58511 Lüdenscheid, Germany - T. +49 2351 661180 - info@thermoplay.de
BELARUS: MOLDELEMENT - str. Zhilunovicha 11, office 202. - 220026 Minsk T. +375172957353 - slvmold@gmail.com
BELGIUM: THERMOPLAY FRANCE - Kamel Guenab, Mob. +33 6 11735429 - guenab@thermoplay.fr
BULGARIA: KRASCO-CO Ltd. - 31 Architect Nenov Str., Lulin Center - Sofia - T. +359 2 9234488 - office@krasco.com
CROATIA: KERN d.o.o., OIC-Hrpelje 41 6240 Kozina, Slovenija - T. + 386 5 616 5006 - info@kern.si
CZECH REPUBLIC: JAN SVOBODA s.r.o. - Přádlácká 599/26, CZ-602 00 BRNO - T. +420 549 243 939 - svoboda@jansvoboda.cz
FRANCE: **Secteur Nord:** THERMOPLAY FRANCE s.a.r.l. - Kamel Guenab - Mob. +33 6 11735429 - guenab@thermoplay.fr
Secteur Ouest: THERMOPLAY FRANCE s.a.r.l. - Patrick Adawi - Mob. +33 (0)6 23 02 04 29 - adawi@thermoplay.fr
Secteur Sud-Est: THERMOPLAY FRANCE s.a.r.l. - Emmanuel Richards - Mob : +33 6 23 02 04 19 - richards@thermoplay.fr
GERMANY: THERMOPLAY DEUTSCHLAND GmbH - Hoffmeisterstrasse, 15 D 58511 Lüdenscheid, Germany - T. +49 2351 661180 - info@thermoplay.de
GREECE: JOSEPH N. AVATAGELOS & CO. - 22 Skra Str. - 14342 N. Filadelfia - T. +30 210 2712912 - avatag@tellas.gr
HUNGARY: THERMAFER - Váci út 184 - 1138 Budapest - T. +36 1 4120935 - thermafer@thermafer.com
ITALY: THERMOPLAY S.p.a. Via Carlo Viola, 74 11026 Pont Saint Martin (AO), Italy - T. +39 0125 800311 r.a. - thermoplay@thermoplay.com - www.thermoplay.com
LUXEMBURG: THERMOPLAY FRANCE - Kamel Guenab, Mob. +33 6 11735429 - guenab@thermoplay.fr
POLAND: A. MARCINIAK OT SP. Z.O.O. 05-500 Nowa iwiczna, Ul. Kraskiego 64 - T.+48 22 736 57 57 - Fax +48 22 736 57 66 - biuro@marciniak.pl - www.marciniak.pl
PORTUGAL: THERMOPLAY PORTUGAL Unipessoal Lda, Rua Dr. Manuel Ribeiro De Oliveira R/C Esq. -2400-178 Leiria, Portugal - T. + 351 244 577 247 - geral@thermoplay.pt
ROMANIA: PLASTIC SYSTEMS SRL - Str. Soseaua Alba Iulia nr.110 - 550052 Sibiu - T. +40 269 229685 - info@plasticsystems.ro
RUSSIA: AB UNIVERSAL - Kashirskiy proezd, 13 - Moscow 115201 - T.+7 495 3800515 / +7 499 6135441 - abuniver@niit.ru
SERBIA MONTENEGRO: NENEL GROUP D.O.O. - Vuka Karadžića 1b, 32300 Gornji Milanovac - T. +381 32 722 070 - info@nenelgroup.com
SLOVENIA: KERN d.o.o. - OIC-Hrpelje 41 6240 Kozina - T. + 386 5 616 5006 - info@kern.si
SPAIN: O.C. SYSTEMS S.L. - Parc industrial Pallejà 1 - Ronda Sta.Eulalia, 35-37 Nau 10 - 08780, PALLEJÀ (BARCELONA) T. +34 9 33387353 - 93 3371858 - ocsystems@ocsystems.es
SWEDEN: KENSON FORMNINGSTEKNIK AB - Kristineholmsvägen 26 - 441 23 Alingsås - T. +46 322 637890 - info@kenson.se
SWITZERLAND: **Canton TI:** THERMOPLAY S.p.A. - GIANLUCA MOZZATO , Via Carlo Viola, 74 - 11026 Pont Saint-Martin (AO), Italy - T. +39 349 2285336 - g.mozzato@thermoplay.com
SWITZERLAND: **Canton VD/VS/GE/JU:** THERMOPLAY FRANCE - Emmanuel Richards, Mob : +33 6 23 02 04 19 - richards@thermoplay.fr
SWITZERLAND: **Other Cantons:** THERMOPLAY DEUTSCHLAND GmbH - Hoffmeisterstrasse, 15 - D 58511 Lüdenscheid, Germany - T. +49 2351 661180 - info@thermoplay.de
THE NETHERLANDS: THERMOPLAY DEUTSCHLAND GmbH - Hoffmeisterstrasse, 15 - D 58511 Lüdenscheid, Germany - T. +49 2351 661180 - info@thermoplay.de
TURKEY: TEKNOFORM KALIP COZUMLERI LTD. STI. Halil Rifat Pasa Mah. Perpa Tic. Mrk. B Blok Kat: 5 No: 119, Sisli Istanbul - T.+90 2123201270 - teknoformltd@superonline.com
UK: THERMOPLAY U.K. Ltd.- Matthew Moss, T. +44 1702 473876 - m.moss@thermoplay.co.uk



Network

AMERICAS

- ARGENTINA:** TORBELAR S.A. Av. Ader 2873 Munro - B1606DUO - Buenos Aires - Argentina T. +54 11 4580-6515 - info@torbelar.com
- BRASIL:** THERMOPLAY BRASIL Sistemas de Injeção LTDA Rua Wallace Barnes, 301 Distrito industrial - Expedição sala 2, 13054-701 Campinas - SP - Brazil T.: +55 19 37251094 - thermoplaybr@thermoplay.com
- COLOMBIA:** REGIN LTDA - Calle 11A No. 72B - 56, Bogotá, D.C. Colombia, South América T. +57 1 4127625 - 4123736 - regin@regin.com.co
- MEXICO:** GRUPO PROINTEC - Arroz # 74, Loc. A - Col. Santa Isabel Industrial - Iztapalapa, C.P. 09820 - Ciudad de Mexico, Mexico - T. 00 52 55 5523-2186 - 00 52 55 5523-2267 c.steta@grupointec.com
- PERU:** DIAMOLD E.I.R.L. Jr tupac Amaru Mz "A" Lt 14 - Independencia - Lima - PERU - T. +51 1 2504290 +511 34 1525 - diamold.project@gmail.com
- U.S.A.:** MAENNER USA Inc. 1105 Progress Industrial Blvd. Lawrenceville GA 30043 USA - Tel.: +1 770-449-1820 Fax: +1 770-449 1821 - info@maenner-group.com

ASIA

- CHINA:** SYNVENTIVE MOLDING SOLUTIONS (Suzhou) Co. Ltd. - 12B Gang Tian Industrial Square Suzhou Industrial Park, Suzhou 215021, PRC - T. +86 512 6283 8870 Fax +86 512 6283 8890 - infohrcn@synventive.com
- INDIA:** THERMOPLAY INDIA Private Limited 1st Floor, "Casa Fernandes" Kamat Kinara Lane, Miramar - Panaji GOA-403 002, India T. +91 832 2461155/2461156 info@thermoplay.in
- INDONESIA:** SYNVENTIVE INDONESIA - Ciputra World One, DBS Bank Tower Level 28 Jl. Prof. Dr. Satrio Kav. 3 - 5 Jakarta 12940 HP: +62 0 21 2988 8401 - Fax: +62 0 21 2988 8201 infohrth@synventive.com
- JAPAN:** SYNVENTIVE MOLDING SOLUTIONS K.K. 6F of Masuni No. 1 Building, 2-4-6 Shin-Yokohama Kouhoku-ku, Yokohama City, Kanagawa Pref. Japan 222-0033 T: +81 0 45 472 1239 - Fax: +81 0 45 472 1163 - infohrjp@synventive.com
- KOREA:** SYNVENTIVE MOLDING SOLUTIONS Pte Ltd. Korea Branch #1102, A BLDG, Daesung D-polis, #606 Seobusaet-gil, Geumcheon-Gu, Korea 08504 - T: +82 2 861 9241-2 Fax: +82 2 861 9243 - infohrkr@synventive.com
- MALAYSIA:** SYNVENTIVE MOLDING SOLUTIONS Pte Ltd. Block 5000, Techplace II #04-10, Ang Mo Kio Ave 5, Singapore 569870 T.: +6017 7080550, Malaysia - infohrml@synventive.com
- SINGAPORE:** SYNVENTIVE MOLDING SOLUTIONS Pte Ltd. Block 5000, Techplace II #04-10, Ang Mo Kio Ave 5, Singapore 569870 T.: +65 6536 8093 - Fax: +65 6536 5660 infohrsg@synventive.com
- TAIWAN:** SYNVENTIVE MOLDING SOLUTIONS Pte Ltd. Block 5000, Techplace II #04-10, Ang Mo Kio Ave 5, Singapore 569870 T.: +886 955659280 (Taiwan) - infohrtw@synventive.com
- THAILAND:** SYNVENTIVE THAILAND Unit A3, 3rd Floor, Goldenland Pavilion Building 153/3 Soi Mahardlekluang 1, Rajdamri Road Lumpini, Pathumwan, Bangkok 10330 - Thailand T.: +66 0 2 652 1411 - infohrth@synventive.com
- VIETNAM:** SYNVENTIVE MOLDING SOLUTIONS Pte Ltd. Block 5000, Techplace II #04-10, Ang Mo Kio Ave 5, Singapore 569870 T.: +65 6536 8093 - Fax: +65 6536 5660 infohrsg@synventive.com

MIDDLE EAST

- ISRAEL:** ANTECH INDUSTRIAL TECHNOLOGIES Ltd. 7 Gilboa street, Moshav Bnei Dror, 4581500, Israel - T.: +972 9 7968689 - Fax: +972 9 7968669 - alon@antech.co.il
- JORDAN:** JORDAN NATIONAL OFFICE OF COMMERCE - P.O. Box 921165 - Amman - T. +962 6 5603903 - jnoc@joinnet.com.jo
- SAUDI ARABIA:** MIDDLE EAST MOLD & DIE FACTORY LTD. - 2nd City P.O. Box 58396 - 11594 Riyadh - T. +966 12652366 - memdf@memdf.net

AFRICA

- ALGERIA:** FS DZAYER - Cité 1200 logts, Résidence El-Khayam, Bloc A app. N° 5, Bab-Ezzouar 16110, Alger - Algérie T. +213 (0) 560 96 17 94 / 550 96 17 24 - contact@fs-dzayer.com
- EGYPT:** MASRIA ELECTRIC CO. - 19-79 Masria Center (1), 10th Ramadan City. A.R.E. - T. +2-02-25887005/25895858 - info@masriaelectric.net
- MOROCCO:** FS MAROC SARL AU C/O AMDE Angle Bd Abdelmoumen & street Soumaya, Rés. Shehrazade 3, 5th floor, Appt N° 22, 20340 Palmiers - Casablanca - MAROC T.: +212 (0) 522 985 460 - M.: +212 (0) 604 509 828 - Fax: +212 (0) 522 359 481 - info@fs-maroc.com
- REP. OF S. AFRICA:** THERMON SOUTH AFRICA (Pty) Ltd. 47, Flamingo Crescent - Landsdowne - 7780 Cape Town T. +27 21 7628995 - sales.za@thermon.com
- TUNISIA:** FLUIDES SERVICES - Immeuble SAADI, Tour E-F Apt N°12 - Cité Mahrajane 1082, Tunis - Tunisie T. (+216) 71 23 31 36 / 71 43 20 29 - Fax: (+216) 71 76 69 82 - info@fs-tn.com

OCEANIA

- NEW ZEALAND:** MOLD TECHNOLOGY LTD. - Po Box 34-785 Birkenhead 0746, Auckland - T. +64 9 833 6194 - info@moldtech.co.nz

THERMOPLAY S.p.a.
Via Carlo Viola, 74
11026 Pont Saint Martin (AO) Italy
Tel.: +39 0125 800311 - thermoplay@thermoplay.com

THERMOPLAY FRANCE S.a.r.l.
Tel.: +39 0125 800311
Fax.: +39 0125 805567/806271
info@thermoplay.fr

THERMOPLAY DEUTSCHLAND GmbH
Hoffmeisterstrasse 15 - 58511 Lüdenscheid, Germany
Tel.: +49 2351 661180 - info@thermoplay.de

THERMOPLAY U.K. Ltd.
Tel.: +44 1702 473876
Fax.: +39 0125 805567/806271
thermoplay@thermoplay.co.uk

THERMOPLAY
HotRunnerSystems

 A business of BARNES GROUP INC



THERMOPLAY PORTUGAL Unipessoal Lda
Rua Dr. Manuel Ribeiro De Oliveira R/C Esq., 2400-178 Leiria, Portugal
Tel.: +351 244 577247 - geral@thermoplay.pt

THERMOPLAY USA
1105 Progress Industrial Blvd.
Lawrenceville GA 30043 USA - Tel.: +1 770-449-1820
Fax: +1 770-449 1821 - info@maenner-group.com

THERMOPLAY ASIA
12B Gang Tian Industrial Square
Suzhou Industrial Park, China 215021
T:+86 512 6283 8870 - info@rcn@synventive.com

THERMOPLAY BRASIL Sistemas de Injeção Ltda
Rua Wallace Barnes 301, 13054-701 Campinas, SP, Brasil
Tel.: +55 19 3725 1094 - thermoplaybr@thermoplay.com

THERMOPLAY INDIA Private Limited
1st Floor "Casa Fernandes" - Kamat Kinara Lane
Miramar-Panaji, GOA-403 002, India
Tel. +91 832 2461155 / 2461156 - info@thermoplay.in

www.thermoplay.com

ALGERIA ARGENTINA AUSTRIA BELARUS BELGIUM BRASIL BULGARIA CANADA CHILE CHINA COLOMBIA
CROATIA CZECH REPUBLIC EGYPT FRANCE GERMANY GREECE HUNGARY INDIA INDONESIA ISRAEL ITALY JAPAN
JORDAN KOREA LUXEMBURG MALAYSIA MEXICO NEW ZEALAND PERU POLAND PORTUGAL REP. OF SOUTH AFRICA
ROMANIA RUSSIA SAUDI ARABIA SERBIA MONTENEGRO SINGAPORE SLOVENIA SPAIN SWEDEN
SWITZERLAND TAIWAN THAILAND THE NETHERLANDS TUNISIA TURKEY UNITED KINGDOM USA VIETNAM